

NF750-G55 series

MS-7578 (v1.x) Mainboard



Copyright Notice

The material in this document is the intellectual property of **MICRO-STAR INTERNATIONAL**. We take every care in the preparation of this document, but no guarantee is given as to the correctness of its contents. Our products are under continual improvement and we reserve the right to make changes without notice.

Trademarks

All trademarks are the properties of their respective owners.

- MSI® is registered trademark of Micro-Star Int'l Co.,Ltd.
- NVIDIA® is registered trademark of NVIDIA Corporation.
- ATI® is registered trademark of ATI Technologies, Inc.
- AMD® is registered trademarks of AMD Corporation.
- Intel® is registered trademarks of Intel Corporation.
- Windows® is registered trademarks of Microsoft Corporation.
- AMI® is registered trademark of American Megatrends, Inc.
- Award® is a registered trademark of Phoenix Technologies Ltd.
- Sound Blaster® is registered trademark of Creative Technology Ltd.
- Realtek® is registered trademark of Realtek Semiconductor Corporation.
- JMicron® is registered trademark of JMicron Technology Corporation.
- Netware® is a registered trademark of Novell, Inc.

Revision History

Revision	Revision History	Date
V1.0	First release for NF750-G55	July 2009

Technical Support

If a problem arises with your system and no solution can be obtained from the user's manual, please contact your place of purchase or local distributor. Alternatively, please try the following help resources for further guidance.

- Visit the MSI website for FAQ, technical guide, BIOS updates, driver updates, and other information: <http://www.msi.com/index.php?func=service>
- Contact our technical staff at: <http://ocss.msi.com>

Safety Instructions

- Always read the safety instructions carefully.
- Keep this User's Manual for future reference.
- Keep this equipment away from humidity.
- Lay this equipment on a reliable flat surface before setting it up.
- The openings on the enclosure are for air convection hence protects the equipment from overheating. **DO NOT COVER THE OPENINGS.**
- Make sure the voltage of the power source and adjust properly 110/220V before connecting the equipment to the power inlet.
- Place the power cord such a way that people can not step on it. Do not place anything over the power cord.
- Always Unplug the Power Cord before inserting any add-on card or module.
- All cautions and warnings on the equipment should be noted.
- Never pour any liquid into the opening that could damage or cause electrical shock.
- If any of the following situations arises, get the equipment checked by service personnel:
 - The power cord or plug is damaged.
 - Liquid has penetrated into the equipment.
 - The equipment has been exposed to moisture.
 - The equipment does not work well or you can not get it work according to User's Manual.
 - The equipment has dropped and damaged.
 - The equipment has obvious sign of breakage.

DO NOT LEAVE THIS EQUIPMENT IN AN ENVIRONMENT UNCONDITIONED, STORAGE TEMPERATURE ABOVE 600 C (1400F), IT MAY DAMAGE THE EQUIPMENT.

CAUTION: Danger of explosion if battery is incorrectly replaced.

Replace only with the same or equivalent type recommended by the manufacturer.

警告使用者:

這是甲類資訊產品，在居住的環境中使用時，可能會造成無線電干擾，在這種情況下，使用者會被要求採取某些適當的對策。



廢電池請回收

For better environmental protection, waste batteries should be collected separately for recycling special disposal.

FCC-B Radio Frequency Interference Statement

This equipment has been tested and found to comply with the limits for a Class B digital device, pursuant to Part 15 of the FCC Rules. These limits are designed to provide reasonable protection against harmful interference in a residential installation. This equipment generates, uses and can radiate radio frequency energy and, if not installed and used in accordance with the instructions, may cause harmful interference to radio communications. However, there is no guarantee that interference will not occur in a particular installation. If this equipment does cause harmful interference to radio or television reception, which can be determined by turning the equipment off and on, the user is encouraged to try to correct the interference by one or more of the measures listed below.



- Reorient or relocate the receiving antenna.
- Increase the separation between the equipment and receiver.
- Connect the equipment into an outlet on a circuit different from that to which the receiver is connected.
- Consult the dealer or an experienced radio/television technician for help.

Notice 1

The changes or modifications not expressly approved by the party responsible for compliance could void the user's authority to operate the equipment.

Notice 2

Shielded interface cables and A.C. power cord, if any, must be used in order to comply with the emission limits.

VOIR LA NOTICE D'INSTALLATION AVANT DE RACCORDER AU RESEAU.

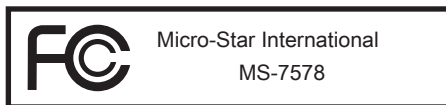

This device complies with Part 15 of the FCC Rules. Operation is subject to the following two conditions:

1. this device may not cause harmful interference, and
2. this device must accept any interference received, including interference that may cause undesired operation.

WEEE (Waste Electrical and Electronic Equipment) Statement

ENGLISH

To protect the global environment and as an environmentalist, MSI must remind you that...



Under the European Union ("EU") Directive on Waste Electrical and Electronic Equipment, Directive 2002/96/EC, which takes effect on August 13, 2005, products of "electrical and electronic equipment" cannot be discarded as municipal waste anymore and manufacturers of covered electronic equipment will be obligated to take back such products at the end of their useful life. MSI will comply with the product take back requirements at the end of life of MSI-branded products that are sold into the EU. You can return these products to local collection points.

DEUTSCH

Hinweis von MSI zur Erhaltung und Schutz unserer Umwelt

Gemäß der Richtlinie 2002/96/EG über Elektro- und Elektronik-Altgeräte dürfen Elektro- und Elektronik-Altgeräte nicht mehr als kommunale Abfälle entsorgt werden. MSI hat europaweit verschiedene Sammel- und Recyclingunternehmen beauftragt, die in die Europäische Union in Verkehr gebrachten Produkte, am Ende seines Lebenszyklus zurückzunehmen. Bitte entsorgen Sie dieses Produkt zum gegebenen Zeitpunkt ausschliesslich an einer lokalen Altgerätesammelstelle in Ihrer Nähe.

FRANÇAIS

En tant qu'écologiste et afin de protéger l'environnement, MSI tient à rappeler ceci...

Au sujet de la directive européenne (EU) relative aux déchets des équipement électriques et électroniques, directive 2002/96/EC, prenant effet le 13 août 2005, que les produits électriques et électroniques ne peuvent être déposés dans les décharges ou tout simplement mis à la poubelle. Les fabricants de ces équipements seront obligés de récupérer certains produits en fin de vie. MSI prendra en compte cette exigence relative au retour des produits en fin de vie au sein de la communauté européenne. Par conséquent vous pouvez retourner localement ces matériels dans les points de collecte.

РУССКИЙ

Компания MSI предпринимает активные действия по защите окружающей среды, поэтому напоминаем вам, что....

В соответствии с директивой Европейского Союза (ЕС) по предотвращению загрязнения окружающей среды использованным электрическим и электронным оборудованием (директива WEEE 2002/96/EC), вступающей в силу 13 августа 2005 года, изделия, относящиеся к электрическому и электронному оборудованию, не могут рассматриваться как бытовой мусор, поэтому производители вышеперечисленного электронного оборудования обязаны принимать его для переработки по окончании срока службы. MSI обязуется соблюдать требования по приему продукции, проданной под маркой MSI на территории ЕС, в переработку по окончании срока службы. Вы можете вернуть эти изделия в специализированные пункты приема.

ESPAÑOL

MSI como empresa comprometida con la protección del medio ambiente, recomienda: Bajo la directiva 2002/96/EC de la Unión Europea en materia de desechos y/o equipos electrónicos, con fecha de rigor desde el 13 de agosto de 2005, los productos clasificados como “eléctricos y equipos electrónicos” no pueden ser depositados en los contenedores habituales de su municipio, los fabricantes de equipos electrónicos, están obligados a hacerse cargo de dichos productos al término de su período de vida. MSI estará comprometido con los términos de recogida de sus productos vendidos en la Unión Europea al final de su período de vida. Usted debe depositar estos productos en el punto limpio establecido por el ayuntamiento de su localidad o entregar a una empresa autorizada para la recogida de estos residuos.

NEDERLANDS

Om het milieu te beschermen, wil MSI u eraan herinneren dat...

De richtlijn van de Europese Unie (EU) met betrekking tot Vervuiling van Electrische en Electronische producten (2002/96/EC), die op 13 Augustus 2005 in zal gaan kunnen niet meer beschouwd worden als vervuiling. Fabrikanten van dit soort producten worden verplicht om producten retour te nemen aan het eind van hun levenscyclus. MSI zal overeenkomstig de richtlijn handelen voor de producten die de merknaam MSI dragen en verkocht zijn in de EU. Deze goederen kunnen geretourneerd worden op lokale inzamelingspunten.

SRPSKI

Da bi zaštitili prirodnu sredinu, i kao preduzeće koje vodi računa o okolini i prirodnoj sredini, MSI mora da vas podesti da...

Po Direktivi Evropske unije (“EU”) o odbačenju eelektronskoj i električnoj opremi, Direktiva 2002/96/EC, koja stupa na snagu od 13. Avgusta 2005, proizvodi koji spadaju pod “elektronsku i električnu opremu” ne mogu više biti odbačeni kao običan otpad i proizvođači ove opreme biće prinuđeni da uzmu natrag ove proizvode na kraju njihovog uobičajenog veka trajanja. MSI će poštovati zahtev o preuzimanju ovakvih proizvoda kojima je istekao vek trajanja, koji imaju MSI oznaku i koji su prodati u EU. Ove proizvode možete vratiti na lokalnim mestima za prikupljanje.

POLSKI

Aby chronić nasze środowisko naturalne oraz jako firma dbająca o ekologię, MSI przypomina, że...

Zgodnie z Dyrektywą Unii Europejskiej (“UE”) dotyczącą odpadów produktów elektrycznych i elektronicznych (Dyrektywa 2002/96/EC), która wchodzi w życie 13 sierpnia 2005, tzw. “produkty oraz wyposażenie elektryczne i elektroniczne” nie mogą być traktowane jako śmieci komunalne, tak więc producenci tych produktów będą zobowiązani do odbierania ich w momencie gdy produkt jest wycofywany z użycia. MSI wypełni wymagania UE, przyjmując produkty (sprzedawane na terenie Unii Europejskiej) wycofywane z użycia. Produkty MSI będzie można zwracać w wyznaczonych punktach zbiorczych.

TÜRKÇE

Çevreci özelliğiyle bilinen MSI dünyada çevreyi korumak için hatırlatır:

Avrupa Birliği (AB) Kararnamesi Elektrik ve Elektronik Malzeme Atığı, 2002/96/EC Kararnamesi altında 13 Ağustos 2005 tarihinden itibaren geçerli olmak üzere, elektrikli ve elektronik malzemeler diğer atıklar gibi çöpe atılmayacak ve bu elektronik cihazların üreticileri, cihazların kullanım süreleri bittikten sonra ürünleri geri toplamakla yükümlü olacaktır. Avrupa Birliği'ne satılan MSI markalı ürünlerin kullanım süreleri bittiğinde MSI ürünlerin geri alınması isteği ile işbirliği içerisinde olacaktır. Ürünlerinizi yerel toplama noktalarına bırakabilirsiniz.

ČESKY

Záleží nám na ochraně životního prostředí - společnost MSI upozorňuje...

Podle směrnice Evropské unie ("EU") o likvidaci elektrických a elektronických výrobků 2002/96/EC platné od 13. srpna 2005 je zakázáno likvidovat "elektrické a elektronické výrobky" v běžném komunálním odpadu a výrobci elektrických výrobků, na které se tato směrnice vztahuje, budou povinni odebírat takové výrobky zpět po skončení jejich životnosti. Společnost MSI splní požadavky na odebírání výrobků značky MSI, prodávaných v zemích EU, po skončení jejich životnosti. Tyto výrobky můžete odevzdat v místních sběrnách.

MAGYAR

Annak érdekében, hogy környezetünket megvédjük, illetve környezetvédőként fellépve az MSI emlékezteti Önt, hogy ...

Az Európai Unió („EU”) 2005. augusztus 13-án hatályba lépő, az elektromos és elektronikus berendezések hulladékairól szóló 2002/96/EK irányelve szerint az elektromos és elektronikus berendezések többé nem kezelhetőek lakossági hulladékként, és az ilyen elektronikus berendezések gyártói köteleessé válnak az ilyen termékek visszavételére azok hasznos élettartama végén. Az MSI betartja a termékvisszavétellel kapcsolatos követelményeket az MSI márkanev alatt az EU-n belül értékesített termékek esetében, azok élettartamának végén. Az ilyen termékeket a legközelebbi gyűjtőhelyre viheti.

ITALIANO

Per proteggere l'ambiente, MSI, da sempre amica della natura, ti ricorda che....

In base alla Direttiva dell'Unione Europea (EU) sullo Smaltimento dei Materiali Elettrici ed Elettronici, Direttiva 2002/96/EC in vigore dal 13 Agosto 2005, prodotti appartenenti alla categoria dei Materiali Elettrici ed Elettronici non possono più essere eliminati come rifiuti municipali: i produttori di detti materiali saranno obbligati a ritirare ogni prodotto alla fine del suo ciclo di vita. MSI si adegnerà a tale Direttiva ritirando tutti i prodotti marchiati MSI che sono stati venduti all'interno dell'Unione Europea alla fine del loro ciclo di vita. È possibile portare i prodotti nel più vicino punto di raccolta

Contents

Copyright Notice	ii
Trademarks	ii
Revision History.....	ii
Technical Support.....	ii
Safety Instructions	iii
FCC-B Radio Frequency Interference Statement.....	iv
WEEE (Waste Electrical and Electronic Equipment) Statement	v
Chapter 1 Getting Started.....	1-1
Mainboard Specifications	1-2
Mainboard Layout	1-4
Packing Checklist.....	1-5
Chapter 2 Hardware Setup.....	2-1
Quick Components Guide	2-2
CPU (Central Processing Unit)	2-3
Memory	2-6
Power Supply	2-8
Back Panel.....	2-9
Connectors.....	2-11
Switch.....	2-17
Jumpers	2-18
Button.....	2-19
Slots	2-20
LED Status Indicators	2-24
Chapter 3 BIOS Setup.....	3-1
Entering Setup	3-2
The Main Menu	3-4
Standard CMOS Features.....	3-6
Advanced BIOS Features	3-9
Integrated Peripherals.....	3-12
Power Management Setup.....	3-14
H/W Monitor	3-16
Green Power	3-17
BIOS Setting Password.....	3-18
Cell Menu	3-19
User Settings.....	3-25

Load Fail-Safe/ Optimized Defaults	3-27
Appendix A Realtek Audio.....	A-1
Installing the Realtek HD Audio Driver.....	A-2
Software Configuration.....	A-4
Hardware Setup	A-19
Appendix B NVIDIA RAID.....	B-1
Introduction	B-2
RAID Configuration	B-3
Installing Driver	B-7
NVIDIA RAID Utility Installation.....	B-8
Using the NVMediaShield Software.....	B-11
Appendix C Overclocking Center	C-1
Activating Overclocking Center.....	C-2
System Info	C-3
DOT.....	C-5

Chapter 1

Getting Started

Thank you for choosing the **NF750-G55** Series (MS-7578 v1.X) ATX mainboard. The **NF750-G55** Series mainboards are based on **NVIDIA® nForce 750a SLI** single chipset for optimal system efficiency. Designed to fit the advanced **AMD®** processor in **AM3** package processor, the **NF750-G55** Series deliver a high performance and professional desktop platform solution.

MAINBOARD SPECIFICATIONS

Processor Support

- Supports AMD® Phenom II/ Athlon II/ Sempron processors in the AM3 package
(For the latest information about CPU, please visit <http://www.msi.com/index.php?func=cpuform2>)

Hyper Transport

- Supports Hyper Transport(HT) 3.0 Technology

Chipset

- NVIDIA® nForce 750a SLI single chipset

Memory Support

- DDR3 800/ 1066/ 1333/ 1600 (OC) SDRAM (16GB Max)
- 4 DDR3 DIMMs (240pin/ 1.5V)
(For more information on compatible components, please visit <http://www.msi.com/index.php?func=testreport>)

Integrated Graphic

- Integrated Geforce 8200 GPU (for NVIDIA® nForce 750a SLI Chipset)
- Share Memory: up to 512MB

LAN

- Supports LAN 10/100/1000 Fast Ethernet by Realtek® RTL 8211CL

Audio

- Chip integrated by Realtek® ALC889
- Flexible 8-channel audio with jack sensing
- Compliant with Azalia 1.0 Spec

IDE

- 1 IDE port by NVIDIA® nForce 750a SLI
- Supports Ultra DMA 66/100/133, PIO & Bus Master operation mode

SATA

- 5 SATAII ports by NVIDIA® nForce 750a SLI
- Supports 5 SATAII devices
- Supports storage and data transfers at up to 3.0 Gb/s

eSATA

- Supports 1 e-SATA port by NVIDIA® nForce 750a SLI
- Supports storage and data transfers at up to 3.0 Gb/s

Floppy

- 1 floppy port
- Supports 1 FDD with 360 KB, 720 KB, 1.2 MB, 1.44 MB and 2.88 MB

Connectors

- Back panel
 - 1 PS/2 mouse port
 - 1 PS/2 Keyboard port
 - 1 VGA port

- 1 DVI-D port
- 1 HDMI port
- 1 eSATA port
- 1 LAN jack
- 6 USB 2.0 ports
- 6 flexible audio jacks
- On-Board Connectors
 - 3 USB 2.0 connectors
 - 1 SPDIF-Out connector
 - 1 Front Panel Audio connector
 - 1 CD-In connector
 - 1 TPM connector
 - 1 Chassis Intrusion Switch connector
 - 1 Serial port connector
 - 1 Easy OC Switch
 - 1 Power button

Slots

- 2 PCI Express x16 slots (support into two x 8 ports when SLI Enabled)
- 2 PCI Express x1 slots
- 1 PCI slot
- Support 3.3V/ 5V PCI bus Interface

Form Factor

- ATX (30.48cm X 22.38cm)

Mounting

- 6 mounting holes

MAINBOARD LAYOUT

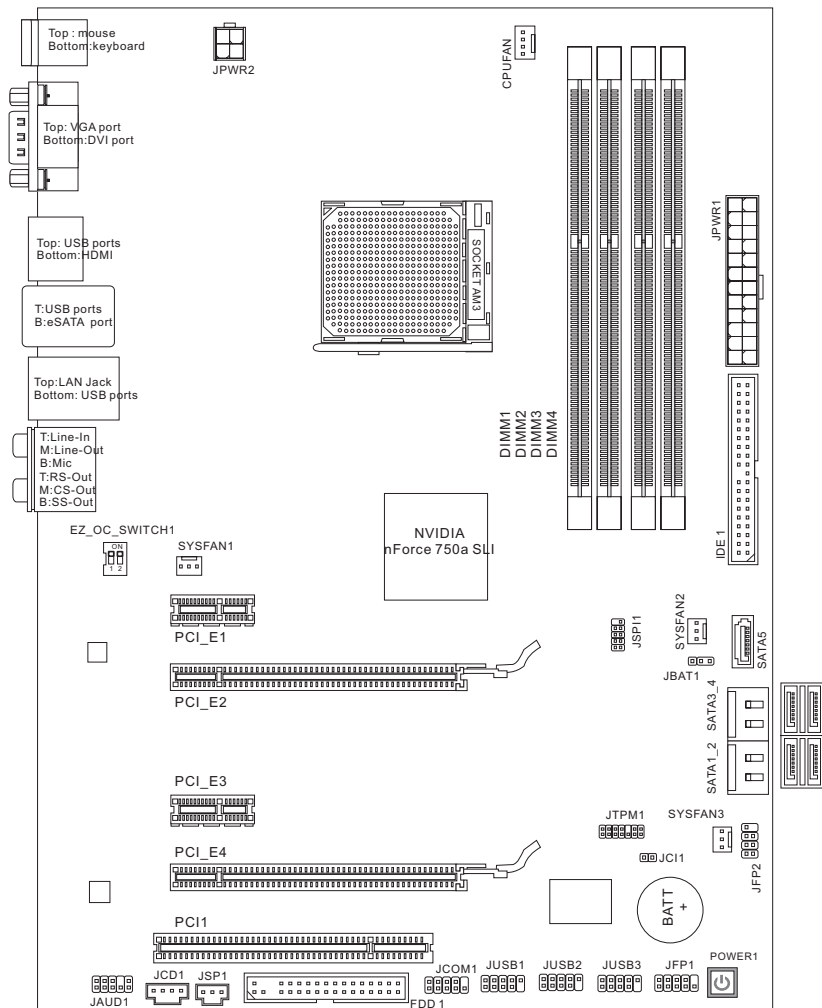

NF750-G55 Series (MS-7578 v1.X) Mainboard

PACKING CHECKLIST



MSI mainboard



MSI Driver/Utility DVD



SATA Cable (Optional)



Power Cable



USB Bracket (Optional)

Standard Cable for
IDE Devices

Back IO Shield



User's Guide

* The pictures are for reference only and may vary from the packing contents of the product you purchased.

* If you need to purchase accessories and request the part numbers, you could search the product web page and find details on our web address below

<http://www.msi.com/index.php>

Chapter 2

Hardware Setup

This chapter provides you with the information about hardware setup procedures. While doing the installation, be careful in holding the components and follow the installation procedures. For some components, if you install in the wrong orientation, the components will not work properly.

Use a grounded wrist strap before handling computer components. Static electricity may damage the components.

QUICK COMPONENTS GUIDE

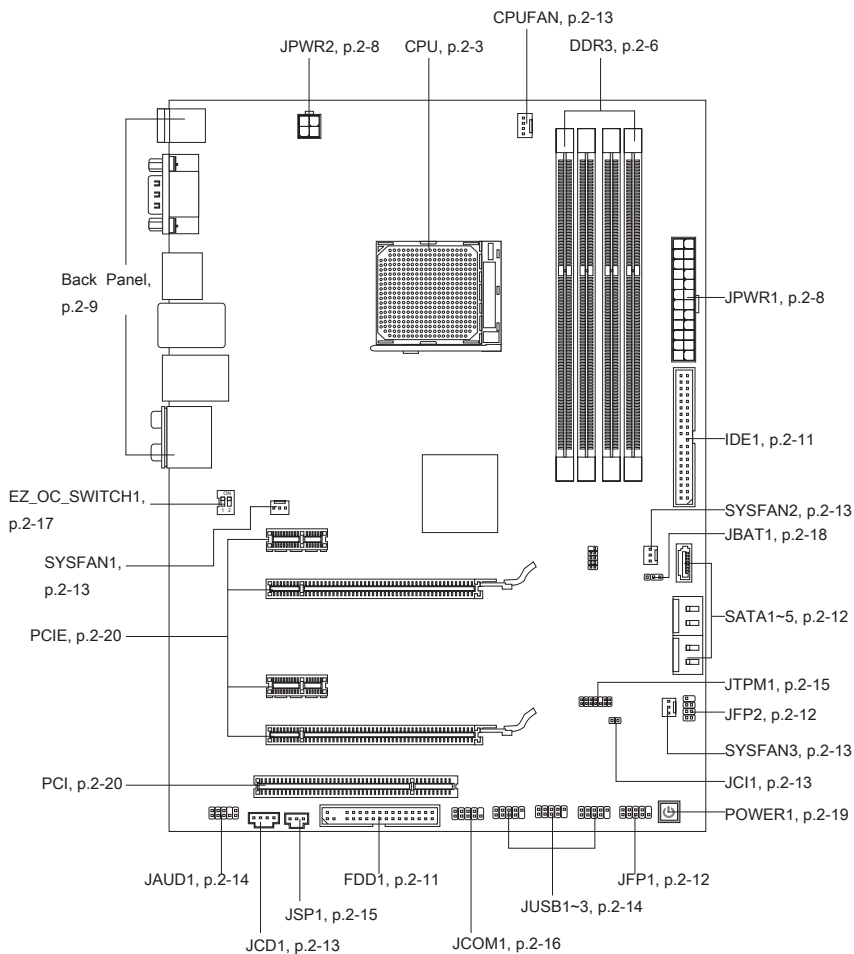

CPU (CENTRAL PROCESSING UNIT)

When you are installing the CPU, make sure to install the cooler to prevent overheating. If you do not have the CPU cooler, consult your dealer before turning on the computer. For the latest information about CPU, please visit <http://www.msi.com/index.php?func=cpuform2>

Important

Overheating

Overheating will seriously damage the CPU and system. Always make sure the cooling fan can work properly to protect the CPU from overheating. Make sure that you apply an even layer of thermal paste (or thermal tape) between the CPU and the heatsink to enhance heat dissipation.

Replacing the CPU

While replacing the CPU, always turn off the ATX power supply or unplug the power supply's power cord from the grounded outlet first to ensure the safety of CPU.

Overclocking

This mainboard is designed to support overclocking. However, please make sure your components are able to tolerate such abnormal setting, while doing overclocking. Any attempt to operate beyond product specifications is not recommended. We do not guarantee the damages or risks caused by inadequate operation or beyond product specifications.

Introduction to AM3 CPU

The surface of CPU. Remember to apply some thermal paste on it for better heat dispersion.



Gold arrow

CPU & Cooler Installation

When you are installing the CPU, make sure the CPU has a cooler attached on the top to prevent overheating. Meanwhile, do not forget to apply some thermal paste on CPU before installing the heat sink/cooler fan for better heat dispersion.

Follow the steps below to install the CPU & cooler correctly. Wrong installation will cause the damage of your CPU & mainboard

1. Pull the lever sideways away from the socket. Make sure to raise the lever up to a 90-degree angle.
2. Look for the gold arrow of the CPU. The gold arrow should point as shown in the picture. The CPU can only fit in the correct orientation.

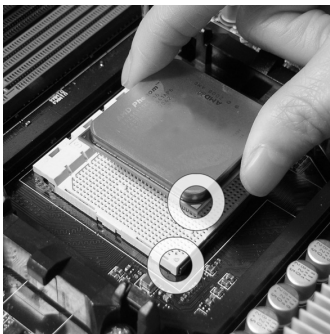
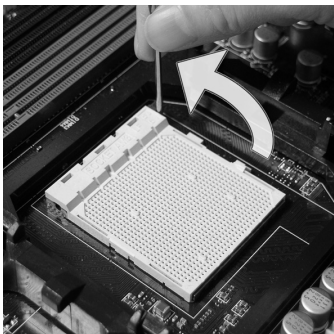

3. If the CPU is correctly installed, the pins should be completely embedded into the socket and can not be seen. Please note that any violation of the correct installation procedures may cause permanent damages to your mainboard.
4. Press the CPU down firmly into the socket and close the lever. As the CPU is likely to move while the lever is being closed, always close the lever with your fingers pressing tightly on top of the CPU to make sure the CPU is properly and completely embedded into the socket.

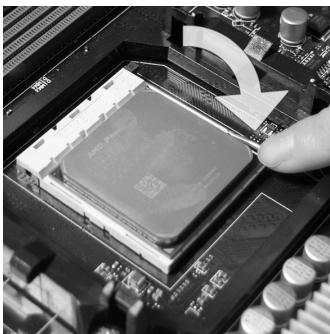
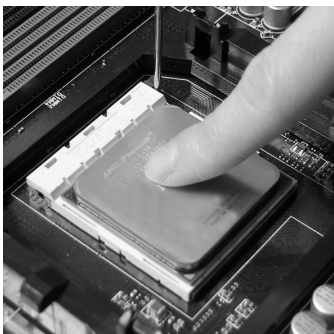

5. Position the cooling set onto the retention mechanism. Hook one end of the clip to hook first.

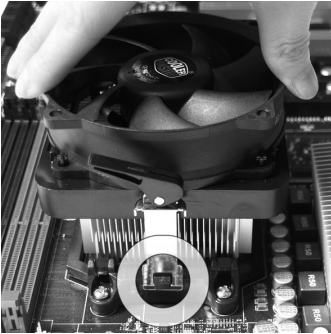

6. Then press down the other end of the clip to fasten the cooling set on the top of the retention mechanism. Locate the Fix Lever and lift up it .

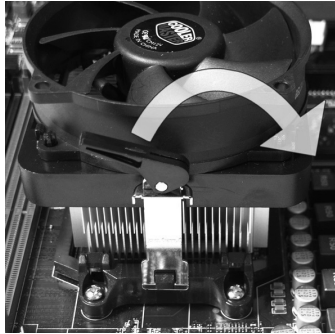

7. Fasten down the lever.

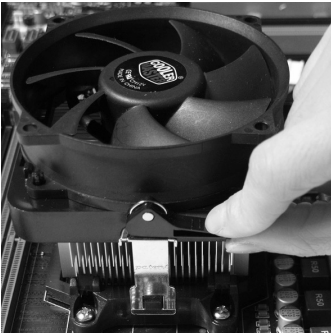

8. Attach the CPU Fan cable to the CPU fan connector on the mainboard.

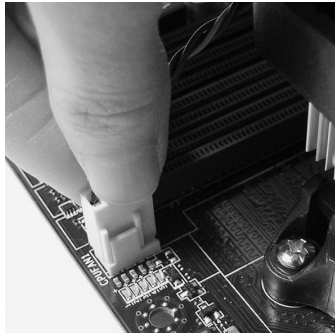

Important

- *Mainboard photos shown in this section are for demonstration only. The appearance of your mainboard may vary depending on the model you purchase.*
- *While disconnecting the Safety Hook from the fixed bolt, it is necessary to keep an eye on your fingers, because once the Safety Hook is disconnected from the fixed bolt, the fixed lever will spring back instantly.*

MEMORY

These DIMM slots are used for installing memory modules.

For more information on compatible components, please visit

<http://www.msi.com/index.php?func=testreport>

DDR3
240-pin, 1.5V

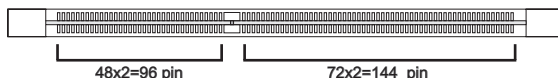

Dual-Channel mode Population Rule

In Dual-Channel mode, the memory modules can transmit and receive data with two data bus lines simultaneously. Enabling Dual-Channel mode can enhance the system performance. The following illustrations explain the population rules for Dual-Channel mode.



①

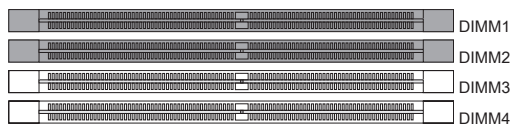

②

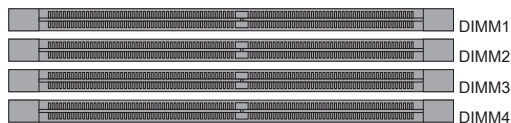

Important

- *DDR3 memory modules are not interchangeable with DDR2 and the DDR3 standard is not backwards compatible. You should always install DDR3 memory modules in the DDR3 DIMM slots.*
- *In Dual-Channel mode, make sure that you install memory modules of the **same type and density** in different channel DIMM slots.*
- *To enable successful system boot-up, always insert the memory modules into the DIMM1 first.*

Installing Memory Modules

1. The memory module has only one notch on the center and will only fit in the right orientation.
2. Insert the memory module vertically into the DIMM slot. Then push it in until the golden finger on the memory module is deeply inserted in the DIMM slot. The plastic clip at each side of the DIMM slot will automatically close when the memory module is properly seated.
3. Manually check if the memory module has been locked in place by the DIMM slot clips at the sides.

Important

You can barely see the golden finger if the memory module is properly inserted in the DIMM slot.

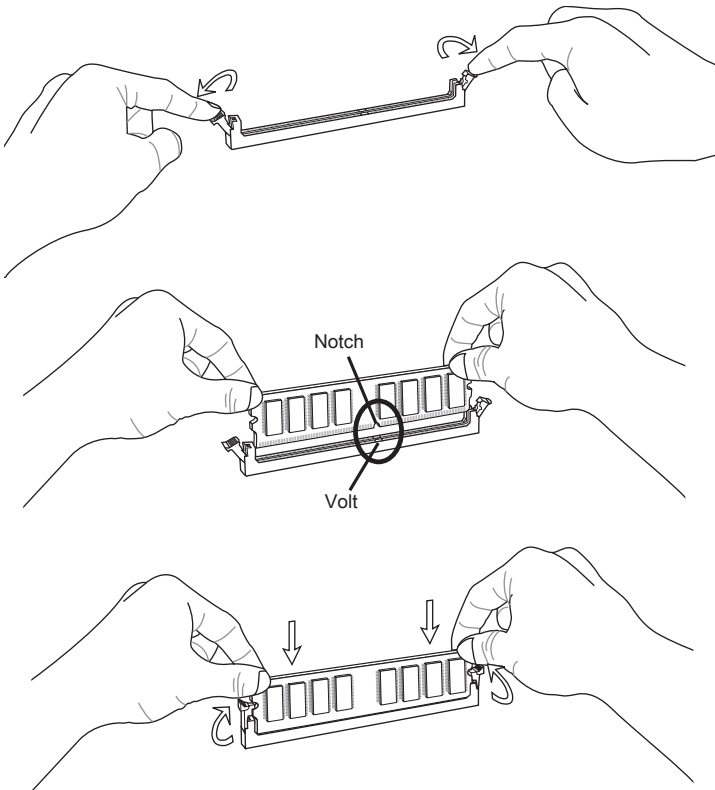

POWER SUPPLY

ATX 24-pin Power Connector: JPWR1

This connector allows you to connect an ATX 24-pin power supply. To connect the ATX 24-pin power supply, make sure the plug of the power supply is inserted in the proper orientation and the pins are aligned. Then push down the power supply firmly into the connector.

You may use the 20-pin ATX power supply as you like. If you'd like to use the 20-pin ATX power supply, please plug your power supply along with pin 1 & pin 13 (refer to the image at the right hand).

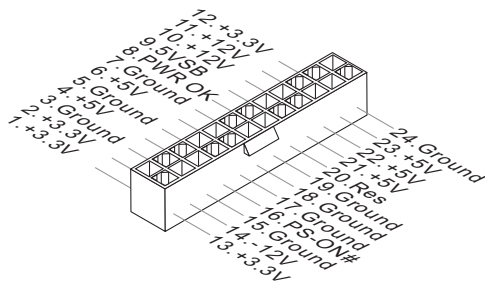

ATX 4-pin Power Connector: JPWR2

This power connector is used to provide power to the CPU.

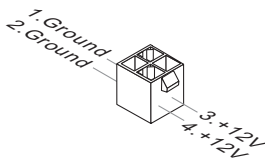

Important

- Make sure that all the connectors are connected to proper ATX power supplies to ensure stable operation of the mainboard.
- Power supply of 350 watts (and above) is highly recommended for system stability.

BACK PANEL

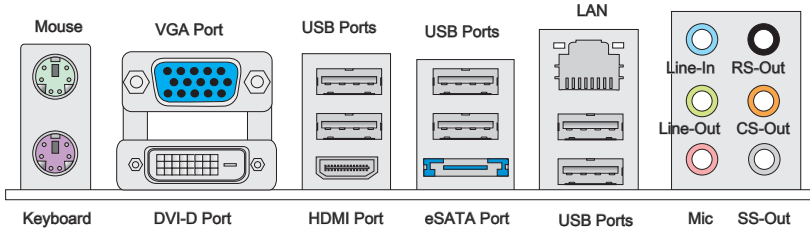

▶ Mouse/Keyboard

The standard PS/2[®] mouse/keyboard DIN connector is for a PS/2[®] mouse/keyboard.

▶ VGA Port

The DB15-pin female connector is provided for monitor.

▶ DVI-D Port

The DVI-D (Digital Visual Interface-Digital) connector allows you to connect a LCD monitor. It provides a high-speed digital interconnection between the computer and its display device. To connect an LCD monitor, simply plug your monitor cable into the DVI-D connector, and make sure that the other end of the cable is properly connected to your monitor (refer to your monitor manual for more information.)

▶ USB Ports

The USB (Universal Serial Bus) port is for attaching USB devices such as keyboard, mouse, or other USB-compatible devices.

▶ HDMI Port

The High-Definition Multimedia Interface (HDMI) is an all-digital audio/video interface capable of transmitting uncompressed streams. HDMI supports all TV format, including standard, enhanced, or high-definition video, plus multi-channel digital audio on a single cable.

▶ eSATA Port

The eSATA port is for attaching the eSATA external hard drive.

▶ LAN

The standard RJ-45 LAN jack is for connection to the Local Area Network (LAN). You can connect a network cable to it.

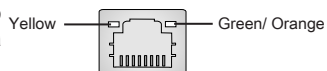

LED	Color	LED State	Condition
Left	Yellow	Off	LAN link is not established.
		On (Steady state)	LAN link is established.
		On (brighter & pulsing)	The computer is communicating with another computer on the LAN.
Right	Green	Off	10 Mbits/sec data rate is selected.
		On	100 Mbits/sec data rate is selected.
	Orange	On	1000 Mbits/sec data rate is selected.

► Audio Ports

These audio connectors are used for audio devices. It is easy to differentiate between audio effects according to the color of audio jacks.

- Line-In (Blue) - Line In, is used for external CD player, tape-player or other audio devices.
- Line-Out (Green) - Line Out, is a connector for speakers or headphones.
- Mic (Pink) - Mic, is a connector for microphones.
- RS-Out (Black) - Rear-Surround Out in 4/ 5.1/ 7.1 channel mode.
- CS-Out (Orange) - Center/ Subwoofer Out in 5.1/ 7.1 channel mode.
- SS-Out (Gray) - Side-Surround Out 7.1 channel mode.

CONNECTORS

Floppy Disk Drive Connector: FDD1

This connector supports 360KB, 720KB, 1.2MB, 1.44MB or 2.88MB floppy disk drive.

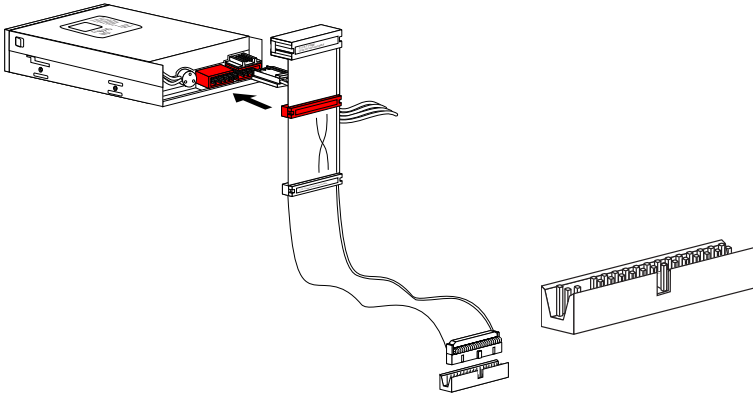

IDE Connector: IDE1

This connector supports IDE hard disk drives, optical disk drives and other IDE devices.

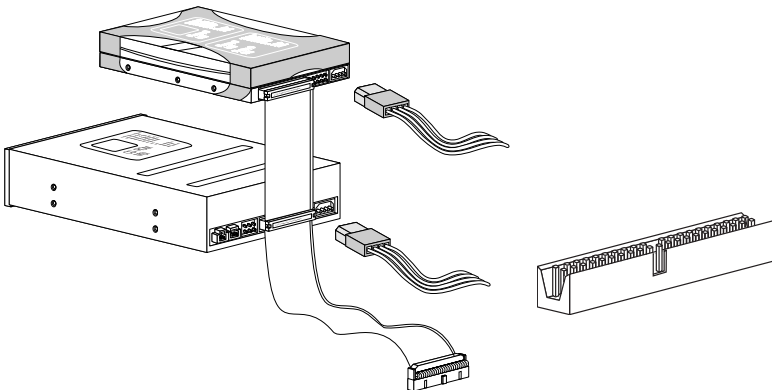

Important

If you install two IDE devices on the same cable, you must configure the drives separately to master / slave mode by setting jumpers. Refer to IDE device's documentation supplied by the vendors for jumper setting instructions.

Serial ATA Connector: SATA1~5

This connector is a high-speed Serial ATA interface port. Each connector can connect to one Serial ATA device.

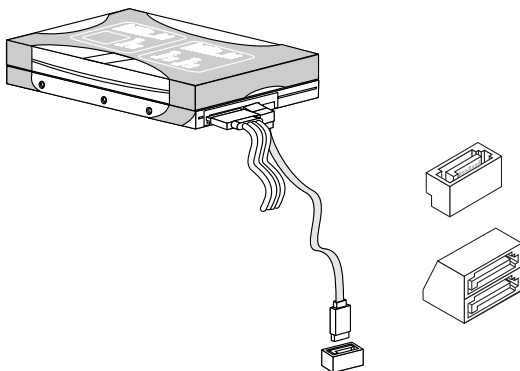

Important

- Please do not fold the Serial ATA cable into 90-degree angle. Otherwise, data loss may occur during transmission.

Front Panel Connector: JFP1, JFP2

This connector is for electrical connection to the front panel switches and LEDs. The JFP1 is compliant with Intel® Front Panel I/O Connectivity Design Guide.

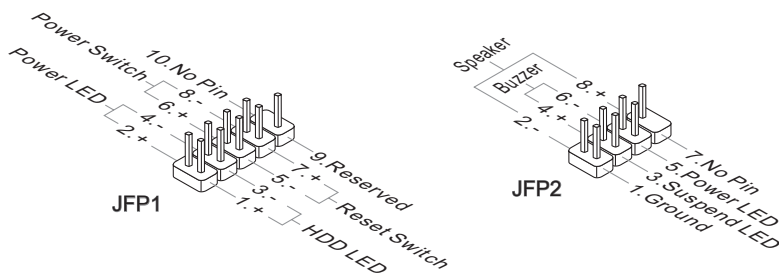

Fan Power Connectors: CPUFAN, SYSFAN1, SYSFAN2/3

The fan power connectors support system cooling fan with +12V. When connecting the wire to the connectors, always note that the red wire is the positive and should be connected to the +12V; the black wire is Ground and should be connected to GND. If the mainboard has a System Hardware Monitor chipset on-board, you must use a specially designed fan with speed sensor to take advantage of the CPU fan control.

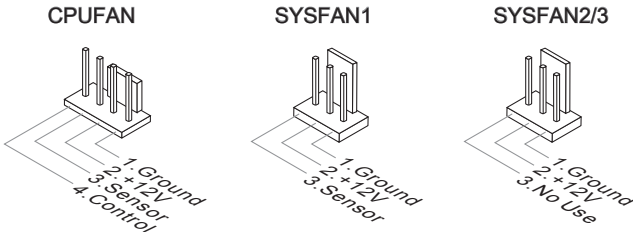

Important

- Please refer to the recommended CPU fans at processor's official website or consult the vendors for proper CPU cooling fan.
- CPUFAN supports fan control. You can install **Overclocking Center** utility that will automatically control the CPU fan speed according to the actual CPU temperature.
- Fan cooler set with 3 or 4 pins power connector are both available for CPUFAN

Chassis Intrusion Connector: JCI1

This connector connects to the chassis intrusion switch cable. If the chassis is opened, the chassis intrusion mechanism will be activated. The system will record this status and show a warning message on the screen. To clear the warning, you must enter the BIOS utility and clear the record.

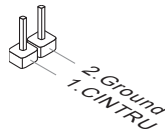

CD-In Connector: JCD1

This connector is provided for external audio input.

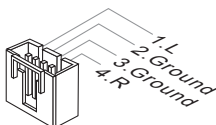

Front USB Connector: JUSB1/ JUSB2/ JUSB3

This connector, compliant with Intel® I/O Connectivity Design Guide, is ideal for connecting high-speed USB interface peripherals such as USB HDD, digital cameras, MP3 players, printers, modems and the like.

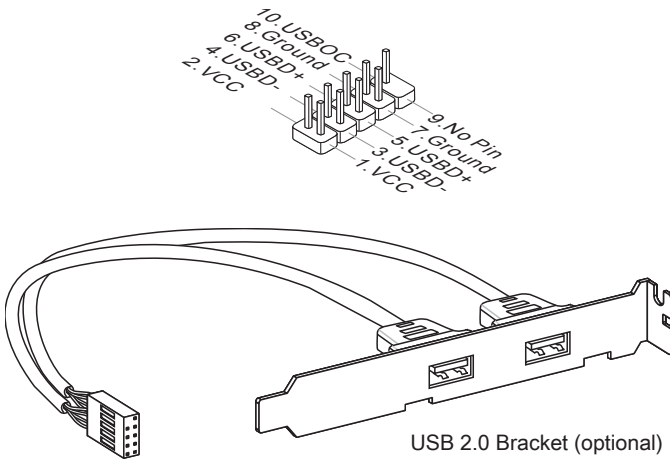

Important

Note that the pins of VCC and GND must be connected correctly to avoid possible damage.

Front Panel Audio Connector: JAUD1

This connector allows you to connect the front panel audio and is compliant with Intel® Front Panel I/O Connectivity Design Guide.

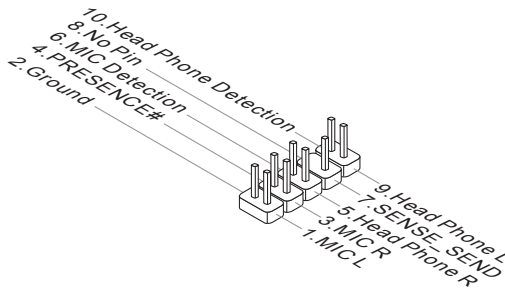

S/PDIF-Out Connector: JSP1

This connector is used to connect S/PDIF (Sony & Philips Digital Interconnect Format) interface for digital audio transmission.

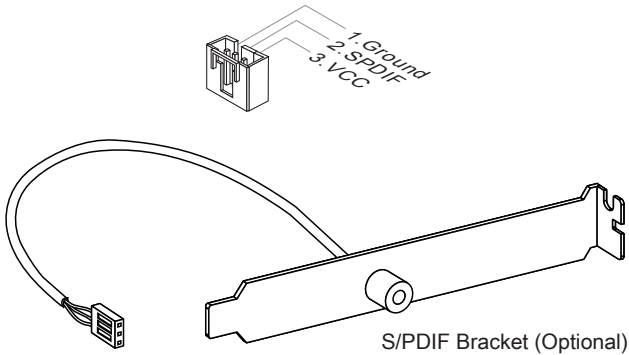

TPM Module connector: JTPM1

This connector connects to a TPM (Trusted Platform Module) module (optional). Please refer to the TPM security platform manual for more details and usages.

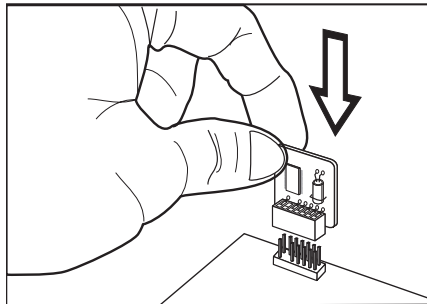
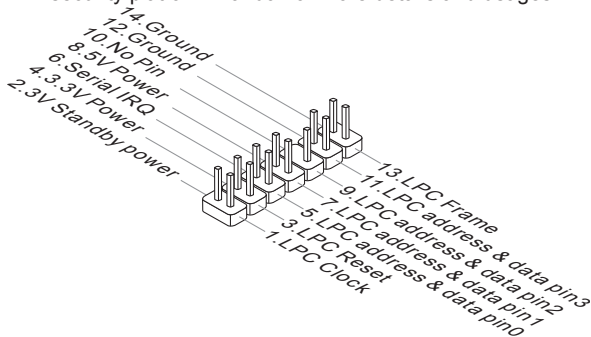

Serial Port Connector: JCOM1

This connector is a 16550A high speed communication port that sends/receives 16 bytes FIFOs. You can attach a serial device.

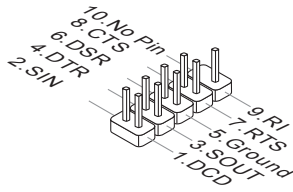

SWITCH

Overclock FSB Switch: EZ_OC_SWITCH1

You can overclock the FSB to increase the processor frequency by changing the switch. Follow the instructions below to set the FSB.



Default



Increase 10%
speed of FSB



Increase 15%
speed of FSB



Increase 20%
speed of FSB

Important

- *Make sure that you power off the system before setting the switch.*
- *When overclocking cause system instability or crash during boot, please set the switch to default setting.*

JUMPERS

Clear CMOS Jumper: JBAT1

There is a CMOS RAM onboard that has a power supply from an external battery to keep the data of system configuration. With the CMOS RAM, the system can automatically boot OS every time it is turned on. If you want to clear the system configuration, set the jumper to clear data.



JBAT1



Keep Data



Clear Data

Important

You can clear CMOS by shorting 2-3 pin while the system is off. Then return to 1-2 pin position. Avoid clearing the CMOS while the system is on; it will damage the mainboard.

BUTTON

The motherboard provides the following button for you to set the computer's function. This section will explain how to change your motherboard's function through the use of button.

Power Button: POWER1

This power button is used to turn-on or turn-off the system. Press the button to turn-on or turn-off the system.



SLOTS

PCI (Peripheral Component Interconnect) Express Slot

The PCI Express slot supports the PCI Express interface expansion card.

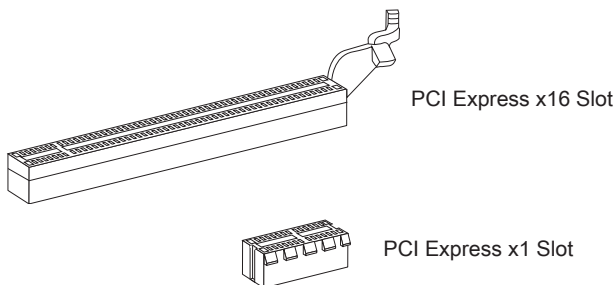

PCI (Peripheral Component Interconnect) Slot

The PCI slot supports LAN card, SCSI card, USB card, and other add-on cards that comply with PCI specifications.

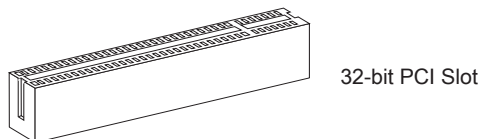

Important

When adding or removing expansion cards, make sure that you unplug the power supply first. Meanwhile, read the documentation for the expansion card to configure any necessary hardware or software settings for the expansion card, such as jumpers, switches or BIOS configuration.

PCI Interrupt Request Routing

The IRQ, acronym of interrupt request line and pronounced I-R-Q, are hardware lines over which devices can send interrupt signals to the microprocessor. The PCI IRQ pins are typically connected to the PCI bus pins as follows:

	Order1	Order2	Order3	Order4
PCI Slot1	INT E#	INT F#	INT G#	INT H#

NVIDIA® SLI Technology

NVIDIA® SLI (Scalable Link Interface) technology allows two GPUs to run in tandem within a system to achieve up to twice the performance of a single graphics card. To utilize this technology, the two GPU cards must be connected by an SLI Video Link Card.

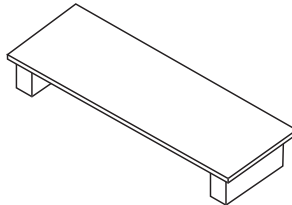

SLI Video Link Card

If you intend to use the SLI mode for better graphics performance, please refer to the following instructions.

1. Install two graphics cards on PCI Express x16 slots. With two cards installed, an SLI Video Link Card is required to connect the golden fingers on the top of these two graphics cards (refer to the picture below). Please note that although you have installed two graphics cards, only the video outputs on the first card will work. Hence, you only need to connect a monitor to the first PCI Express card.

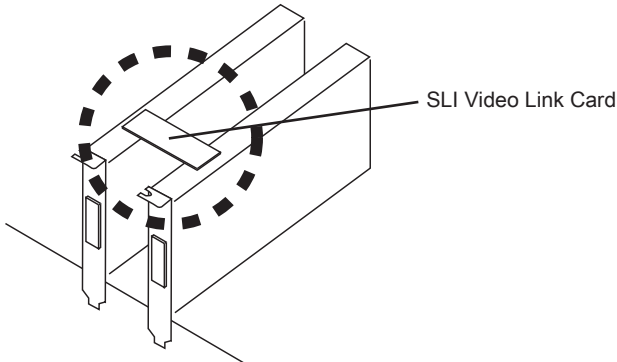

Important

- *The photos shown in this section are for demonstration only. The appearance of your mainboard may vary depending on the model you purchase.*
- *If you intend to install TWO x16 graphics cards, make sure that these two graphics cards are of the same brand and specifications.*
- *Make sure that you connect an adequate power supply to the JPWR2 connector (or to the power connector on the graphics card) to ensure stable operation of the graphics card.*
- *If you intend to install only ONE graphics card, make sure that the graphics card is installed on the first PCIE x16 (PCI_E2) slot.*

- After the hardware installation is completed, restart the system and install the NV SLI driver/utility. A configuration panel will be provided for Multi-GPU control. Check the Enable multi-GPU box to enable the SLI function for the onboard graphics cards (concerning the details of multi-GPU settings, please refer to your graphics card manual).

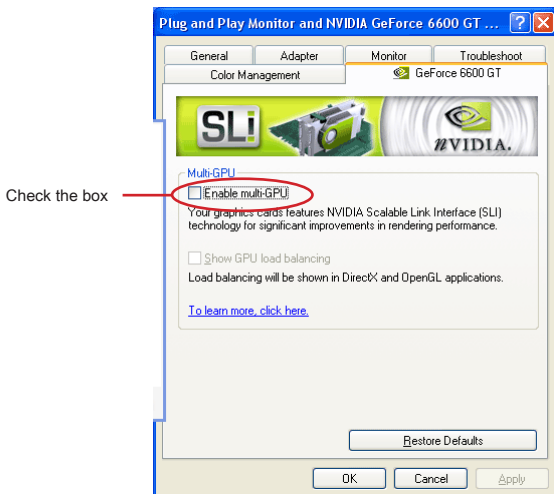

- Restart your system and a pop-up message will show in the system tray confirming the Multi-GPU has been enabled.

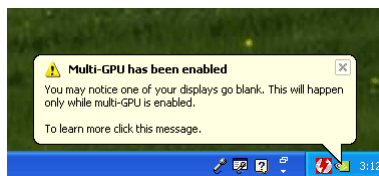

Important

If you want to remove one graphics card and quit the SLI function, make sure the "MultiGPU" function is disabled.

NVIDIA® Hybrid SLI Technology

Hybrid SLI technology, based on NVIDIA®'s industry-leading SLI technology, delivers multi-GPU benefits when an NVIDIA® mainboard GPU is combined with an NVIDIA® discrete GPU.

Enabling Hybrid SLI Technology

Power off the system and install the NVIDIA® SLI graphic card that supports Hybrid SLI technology. After then, power on the system and install the "NVIDIA® hSLI Driver" which supports Windows Vista only. Restart the system and wait for the Hybrid Icon to show in the system tray. The hybrid icon indicates that the system is in Performance mode and that GeForce Boost is enabled. The chipset will share the rendering load with the graphic card and boost the performance of the graphic card.



Click on the Hybrid Icon in the System tray can select the Hybrid mode. The Hybrid modes are listed below.

Hybrid-Performance Mode - The hybrid mode where the discrete GPU (dGPU) and mainboard GPU (mGPU) are simultaneously active and working collaboratively to provide higher performance (GeForce Boost)

Hybrid-Power Mode - The hybrid mode where the dGPU completely shut off and mGPU renders and drives the display (HybridPower).

Important

Please note that although you have installed the graphics card in the PCI Express slot, only the onboard video outputs (which be embedded in back panel of mainboard) will work. Hence, you only need to connect a monitor to the onboard video output.

LED STATUS INDICATORS

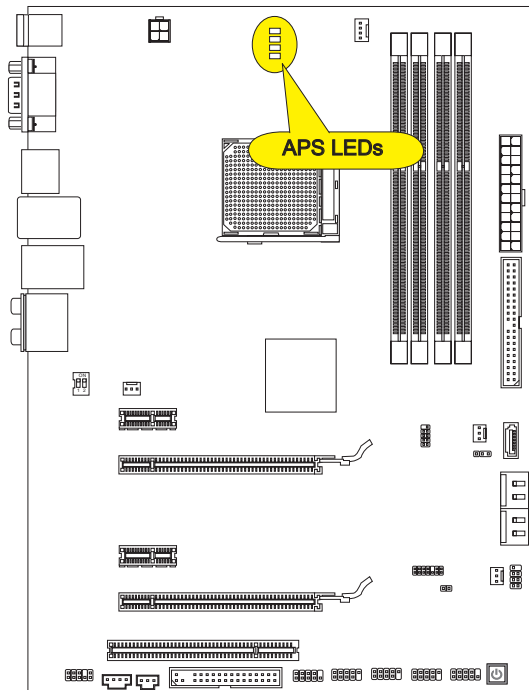

APS LEDs

These APS (Active Phase Switching) LEDs indicate the current CPU power phase mode. Follow the instructions below to read.

■ : ON, □ : OFF



4 of the LEDs will light blue when CPU is in 4 phase power mode.



1 of the LEDs will light blue when CPU is in 1 phase power mode.

Chapter 3

BIOS Setup

This chapter provides information on the BIOS Setup program and allows you to configure the system for optimum use.

You may need to run the Setup program when:

- An error message appears on the screen during the system booting up, and requests you to run SETUP.
- You want to change the default settings for customized features.

ENTERING SETUP

Power on the computer and the system will start POST (Power On Self Test) process. When the message below appears on the screen, press key to enter Setup.

Press DEL to enter SETUP

If the message disappears before you respond and you still wish to enter Setup, restart the system by turning it OFF and On or pressing the RESET button. You may also restart the system by simultaneously pressing <Ctrl>, <Alt>, and <Delete> keys.

Important

- *The items under each BIOS category described in this chapter are under continuous update for better system performance. Therefore, the description may be slightly different from the latest BIOS and should be held for reference only.*
- *Upon boot-up, the 1st line appearing after the memory count is the BIOS version. It is usually in the format:*

A7578AMS V1.0 061709 where:

1st digit refers to BIOS maker as A = AMI, W = AWARD, and P = PHOENIX.

2nd - 5th digit refers to the model number.

6th digit refers to the chipset as I = Intel, N = NVIDIA, A = AMD and V = VIA.

7th - 8th digit refers to the customer as MS = all standard customers.

V1.0 refers to the BIOS version.

060909 refers to the date this BIOS was released.

Control Keys

<↑>	Move to the previous item
<↓>	Move to the next item
<←>	Move to the item in the left hand
<→>	Move to the item in the right hand
<Enter>	Select the item
<Esc>	Jumps to the Exit menu or returns to the main menu from a submenu
<+ /PU>	Increase the numeric value or make changes
<- /PD>	Decrease the numeric value or make changes
<F1>	General Help
<F6>	Load Optimized Defaults
<F8>	Load Fail-Safe Defaults
<F10>	Save all the CMOS changes and exit

Getting Help

After entering the Setup menu, the first menu you will see is the Main Menu.

Main Menu

The main menu lists the setup functions you can make changes to. You can use the arrow keys (↑ ↓) to select the item. The on-line description of the highlighted setup function is displayed at the bottom of the screen.

Sub-Menu

If you find a right pointer symbol (as shown in the right view) appears to the left of certain fields that means a sub-menu can be launched from this field. A sub-menu contains additional options for a field parameter. You can use arrow keys (↑ ↓) to highlight the field and press <Enter> to call up the sub-menu. Then you can use the control keys to enter values and move from field to field within a sub-menu. If you want to return to the main menu, just press the <Esc >.



▶ SATA1
▶ SATA2
▶ SATA3
▶ SATA4

General Help <F1>

The BIOS setup program provides a General Help screen. You can call up this screen from any menu by simply pressing <F1>. The Help screen lists the appropriate keys to use and the possible selections for the highlighted item. Press <Esc> to exit the Help screen.

THE MAIN MENU

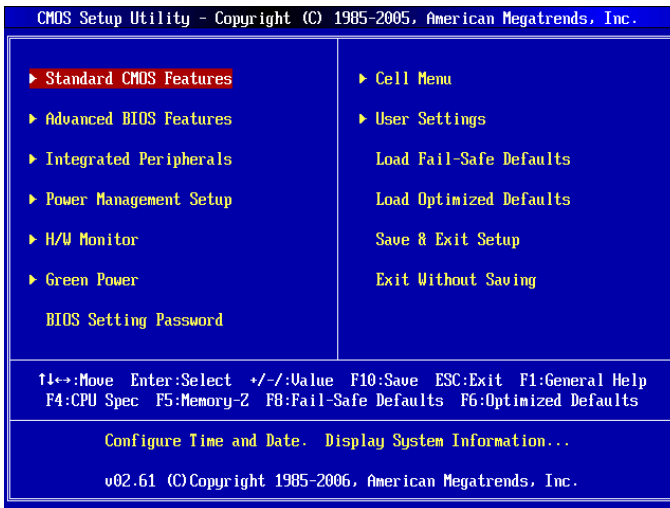

▶ Standard CMOS Features

Use this menu for basic system configurations, such as time, date etc.

▶ Advanced BIOS Features

Use this menu to setup the items of the BIOS special enhanced features.

▶ Integrated Peripherals

Use this menu to specify your settings for integrated peripherals.

▶ Power Management Setup

Use this menu to specify your settings for power management.

▶ H/W Monitor

This entry shows your PC health status.

▶ Green Power

Use this menu to specify the power phase.

▶ BIOS Setting Password

Use this menu to set the password for BIOS.

▶ Cell Menu

Use this menu to specify your settings for frequency/voltage control and overclocking.

▶ User Settings

Use this menu to save/ load your settings to/ from CMOS for BIOS.

► Load Fail-Safe Defaults

Use this menu to load the default values set by the BIOS vendor for stable system performance.

► Load Optimized Defaults

Use this menu to load the default values set by the mainboard manufacturer specifically for optimal performance of the mainboard.

► Save & Exit Setup

Save changes to CMOS and exit setup.

► Exit Without Saving

Abandon all changes and exit setup.

STANDARD CMOS FEATURES

The items in Standard CMOS Features Menu include some basic setup items. Use the arrow keys to highlight the item and then use the <PgUp> or <PgDn> keys to select the value you want in each item.

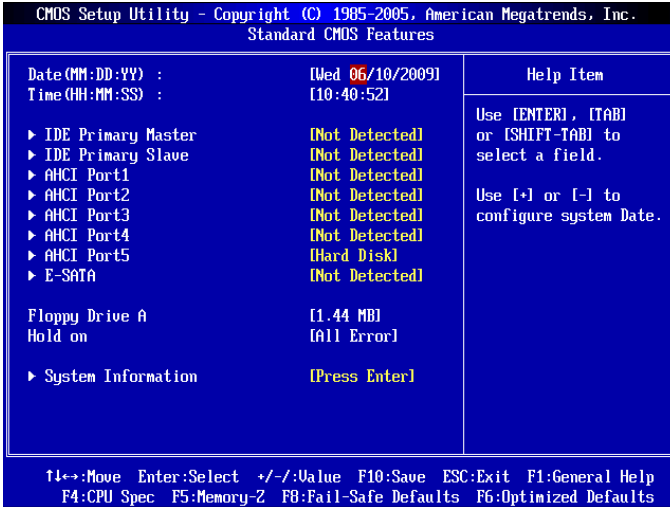

▶ Date (MM:DD:YY)

This allows you to set the system to the date that you want (usually the current date). The format is <day><month> <date> <year>.

- [day] Day of the week, from Sun to Sat, determined by BIOS. Read-only.
- [month] The month from Jan. through Dec.
- [date] The date from 1 to 31 can be keyed by numeric function keys.
- [year] The year can be adjusted by users.

▶ Time (HH:MM:SS)

This allows you to set the system time that you want (usually the current time). The time format is <hour> <minute> <second>.

► IDE Primary Master/ Slave, AHCI Port 1~5 (SATA1~4) & E-SATA

Press <Enter> to enter the sub-menu, and the following screen appears.

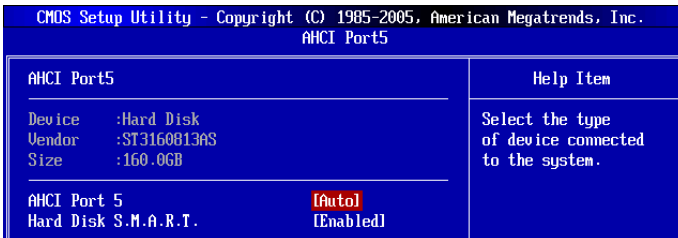

► Device / Vendor / Size

It will show the device information that you connected to the SATA connector.

► LBA/Large Mode

This allows you to enable or disable the LBA Mode. Setting to Auto enables LBA mode if the device supports it and the devices is not already formatted with LBA mode disabled.

► DMA Mode

Select DMA Mode.

► Hard Disk S.M.A.R.T.

This allows you to activate the S.M.A.R.T. (Self-Monitoring Analysis & Reporting Technology) capability for the hard disks. S.M.A.R.T is a utility that monitors your disk status to predict hard disk failure. This gives you an opportunity to move data from a hard disk that is going to fail to a safe place before the hard disk becomes offline.

Important

- IDE Primary Master/ Slave, SATA 1~4 are appearing when you connect the HD devices to the IDE/ SATA connectors on the mainboard. AHCI Port1~5 and E-SATA will appear after you adjust the option to [AHCI Mode] in Integrated Peripherals → On-Chip ATA Device → RAID Mode.
- SATA5 and E-SATA port only can use with ACHI mode and RAID mode.

► Floppy Drive A

This item allows you to set the type of floppy drives installed.

► Halt On

The setting determines whether the system will stop if an error is detected at boot. When the system stops for the errors preset, it will halt on for 15 seconds and then automatically resume its operation. Available options are:

- [All Errors] The system stops when any error is detected.
- [No Errors] The system doesn't stop for any detected error.

► System Information

Press <Enter> to enter the sub-menu, and the following screen appears.

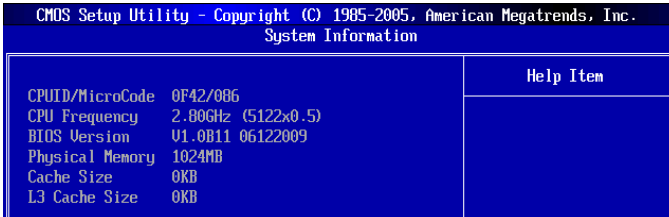

The screenshot shows a BIOS utility window with a black title bar containing the text 'CMOS Setup Utility - Copyright (C) 1985-2005, American Megatrends, Inc.'. Below the title bar is a blue header area with the text 'System Information'. The main content area is a table with a blue background and white text. The table has two columns: the left column lists system information and the right column is labeled 'Help Item'.

System Information	
	Help Item
CPUID/MicroCode	0F42/006
CPU Frequency	2.80GHz (5122x0.5)
BIOS Version	01.0B11 06122009
Physical Memory	1024MB
Cache Size	0KB
L3 Cache Size	0KB

This sub-menu shows the CPU information, BIOS version and memory status of your system (read only).

ADVANCED BIOS FEATURES

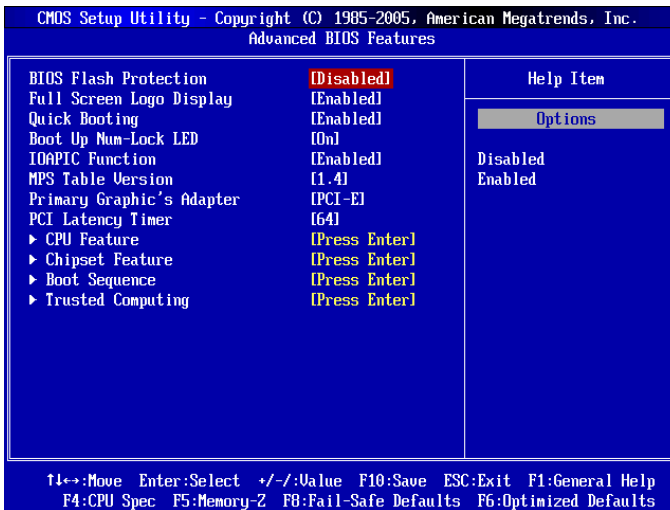

▶ BIOS Flash Protection

This function protects the BIOS from accidental corruption by unauthorized users or computer viruses. When enabled, the BIOS data cannot be changed when attempting to update the BIOS with a Flash utility. To successfully update the BIOS, you will need to disable this Flash BIOS Protection function. You should enable this function at all times. The only time when you need to disable it is when you want to update the BIOS. After updating the BIOS, you should immediately re-enable it to protect it against viruses.

▶ Full Screen Logo Display

This item enables this system to show the company logo on the boot-up screen. Settings are:

- [Enabled] Shows a still image (logo) on the full screen at boot.
- [Disabled] Shows the POST messages at boot.

▶ Quick Booting

Setting the item to [Enabled] allows the system to boot within 10 seconds since it will skip some check items.

▶ Boot Up Num-Lock LED

This setting is to set the Num Lock status when the system is powered on. Setting to [On] will turn on the Num Lock key when the system is powered on. Setting to [Off] will allow users to use the arrow keys on the numeric keypad.

▶ IOAPIC Function

This field is used to enable or disable the APIC (Advanced Programmable Interrupt Controller). Due to compliance with PC2001 design guide, the system is able to run in APIC mode. Enabling APIC mode will expand available IRQ resources for the system.

► MPS Table Version

This field allows you to select which MPS (Multi-Processor Specification) version to be used for the operating system. You need to select the MPS version supported by your operating system. To find out which version to use, consult the vendor of your operating system.

► Primary Graphic's Adapter

This setting specifies which graphic card is your primary graphics adapter.

► PCI Latency Timer

This item controls how long each PCI device can hold the bus before another takes over. When set to higher values, every PCI device can conduct transactions for a longer time and thus improve the effective PCI bandwidth. For better PCI performance, you should set the item to higher values.

► CPU Feature

Press <Enter> to enter the sub-menu and the following screen appears:

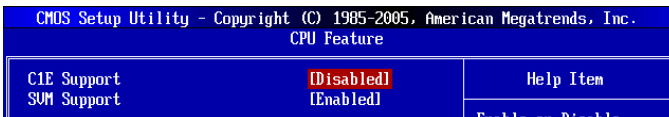

The screenshot shows the BIOS CPU Feature menu. The title bar reads 'CMOS Setup Utility - Copyright (C) 1985-2005, American Megatrends, Inc.' and the menu title is 'CPU Feature'. The menu items are:

		Help Item
C1E Support	[Disabled]	
SVM Support	[Enabled]	Enable or Disable

► C1E Support

To enable this item to reduce the CPU power consumption while idle. Not all processors support Enhanced Halt state (C1E).

► SVM Support

This item is used to enable/ disable SVM.

► Chipset Feature

Press <Enter> to enter the sub-menu and the following screen appears:



The screenshot shows the BIOS Chipset Feature menu. The title bar reads 'CMOS Setup Utility - Copyright (C) 1985-2005, American Megatrends, Inc.' and the menu title is 'Chipset Feature'. The menu items are:

		Help Item
HPET	[Disabled]	
Hybrid SLI support	[Disabled]	
On-Chip VGA	[Disabled]	Options
VGA Share Memory Auto	[Auto]	Disabled

► HPET

The HPET (High Precision Event Timers) is a component that is part of the chipset. You can enable it, and will provide you with the means to get to it via the various ACPI methods.

► Hybrid SLI Support

This item is used to enable/ disable the Hybrid SLI feature.

► On-Chip VGA

This setting allows you to enable or disable the on-chip VGA function.

► VGA Share Memory Auto

This setting controls the exact memory size shared to the VGA card.

► Boot Sequence

Press <Enter> to enter the sub-menu and the following screen appears:

CMOS Setup Utility - Copyright (C) 1985-2005, American Megatrends, Inc.		
Boot Sequence		
1st Boot Device	[USB:Generic F1]	Help Item
2nd Boot Device	[ATA:4S-ST3160]	Specifies the boot sequence from the
Boot From Other Device	[Yes]	

► --- Boot Device

These items allow you to arrange the order that the BIOS uses to look for a boot device from which to load the operating system during the boot process.

► Boot From Other Device

Setting the option to [Yes] allows the system to try to boot from other device, if the system fails to boot from above devices.

► Trusted Computing

Press <Enter> to enter the sub-menu and the following screen appears:

CMOS Setup Utility - Copyright (C) 1985-2005, American Megatrends, Inc.		
Trusted Computing		
TCG/TPM SUPPORT	[No]	Help Item
Clearing the TPM	[Press Enter]	Enable/Disable TPM

► TCG/TPM SUPPORT

Setting the option to [Yes] enables TPM (Trusted Platform Module) to the system.

► Clearing the TPM

Press Enter to clear the TPM status.

INTEGRATED PERIPHERALS

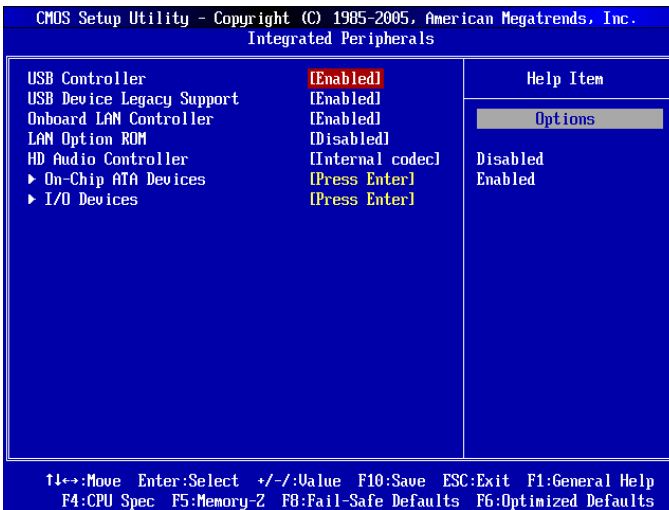

▶ USB Controller

This setting allows you to enable/disable the onboard USB 1.1/ 2.0 controller.

▶ USB Device Legacy Support

Select [Enabled] if you need to use a USB-interfaced device in the operating system.

▶ Onboard LAN Controller

This setting allows you to enable/disable the onboard LAN controller.

▶ LAN Option ROM

This item is used to decide whether to invoke the Boot ROM of the onboard LAN.

▶ HD Audio Controller

This setting is used to select the audio codec.

▶ On-Chip ATA Devices

Press <Enter> to enter the sub-menu and the following screen appears:



▶ On-Chip IDE Controller

This item is used to enable/disable the IDE interface.

▶ **PCI IDE BusMaster**

This item allows you to enable/ disable BIOS to used PCI busmastering for reading/ writing to IDE drives.

▶ **OnChip SATA Controller**

This item allows users to enable or disable the SATA controller.

▶ **RAID Mode**

This item is used to select mode for SATA connectors.

▶ **I/O Devices**

Press <Enter> to enter the sub-menu and the following screen appears:



▶ **COM Port 1**

Select an address and corresponding interrupt for the serial port.

POWER MANAGEMENT SETUP



Important

S3-related functions described in this section are available only when the BIOS supports S3 sleep mode.

▶ ACPI Function

This item is to activate the ACPI (Advanced Configuration and Power Management Interface) Function. If your operating system is ACPI-aware, such as Windows 98SE/2000/ ME/ XP, select [Enabled].

▶ ACPI Standby State

This item specifies the power saving modes for ACPI function. If your operating system supports ACPI, such as Windows 2000/ XP, you can choose to enter the Standby mode in S1(POS) or S3(STR) fashion through the setting of this field. Settings are:

- [S1] The S1 sleep mode is a low power state. In this state, no system context is lost (CPU or chipset) and hardware maintains all system's context.
- [S3] The S3 sleep mode is a lower power state where the information of system configuration and open applications/files is saved to main memory that remains powered while most other hardware components turn off to save energy. The information stored in memory will be used to restore the system when a "wake up" event occurs.

► Power Button Function

This feature sets the function of the power button. Settings are:

- [Power Off] The power button functions as normal power off button.
- [Suspend] When you press the power button, the computer enters suspend/sleep mode, but if the button is pressed for more than four seconds, the computer is turned off.

► Restore On AC Power Loss

This item specifies whether your system will reboot after a power failure or interrupt occurs. Settings are:

- [Off] Always leaves the computer in the power off state.
- [On] Always leaves the computer in the power on state.
- [Last State] Restore the system to the status before power failure or interrupt occurred.

► Wake Up Event Setup

Press <Enter> and the following sub-menu appears.



► Wake Up Event By

Setting to [BIOS] activates the following fields, and use the following fields to set the wake up events. Setting to [OS], the wake up events will be defined by OS.

► Resume From S3 By USB Device

The item allows the activity of the USB device to wake up the system from S3 (Suspend to RAM) sleep state.

► Resume By PCI Device (PME#)

When set to [Enabled], the feature allows your system to be awakened from the power saving modes through any event on PME (Power Management Event).

► Resume By PCI-E Device

When set to [Enabled], the feature allows your system to be awakened from the power saving modes through any event on PCIE device.

► Resume By RTC Alarm

The field is used to enable or disable the feature of booting up the system on a scheduled time/date.

H/W MONITOR

CMOS Setup Utility - Copyright (C) 1985-2005, American Megatrends, Inc.		
H/W Monitor		
Chassis Intrusion	[Disabled]	Help Item
CPU Smart Fan Target	[Disabled]	Chassis Intrusion func
SYS FAN 1 Control	[100%]	
SYS FAN 2 Control	[100%]	
----- PC Health Status -----		
CPU Temperature	66°C/150°F	
System Temperature	28°C/82°F	
CPU FAN Speed	2325 RPM	
SYS FAN 1 Speed	0 RPM	
SYS FAN 2 Speed	0 RPM	
CPU Vcore	1.304 U	
3.3V	3.280 U	
5V	4.961 U	
12V	11.792 U	
↑←→:Move Enter:Select +/-:Value F10:Save ESC:Exit F1:General Help F4:CPU Spec F5:Memory-Z F8:Fail-Safe Defaults F6:Optimized Defaults		

► Chassis Intrusion

The field enables or disables the feature of recording the chassis intrusion status and issuing a warning message if the chassis is once opened. To clear the warning message, set the field to [Reset]. The setting of the field will automatically return to [Enabled] later.

► CPU Smart FAN Target

The mainboard provides the Smart Fan function which can control the CPU fan speed automatically depending on the current temperature to keep it with in a specific range. You can enable a fan target value here. If the current CPU fan temperature reaches to the target value, the smart fan function will be activated. It provides several sections to speed up for cooling down automatically.

► SYS FAN 1/ 2 Control

The field allows you to set the system fan 1/ 2 speed percentage.

► PC Health Status

- CPU/ System Temperature, CPU FAN/ SYS FAN 1/ SYS FAN 2 Speed, CPU Vcore, 3.3V, 5V, 12V

These items display the current status of all of the monitored hardware devices/components such as CPU voltage, temperatures and all fans' speeds.

GREEN POWER

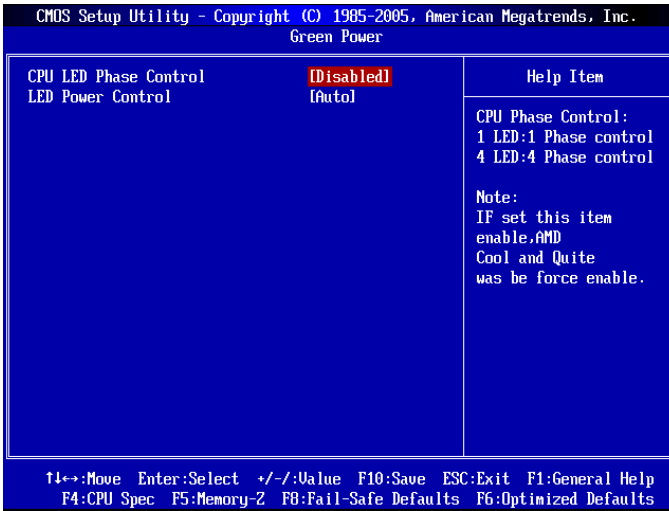

► CPU LED Phase Control

This item allows you to select the amount of CPU phase control that you want to use. Once this item is enabled, the hardware will auto adjust the CPU power phase according to the loading of CPU to reach the best power saving function.

► LED Power Control

This item is used to control the power phase LEDs of the motherboard.

BIOS SETTING PASSWORD

When you select this function, a message as below will appear on the screen:



Type the password, up to six characters in length, and press <Enter>. The password typed now will replace any previously set password from CMOS memory. You will be prompted to confirm the password. Retype the password and press <Enter>. You may also press <Esc> to abort the selection and not enter a password.

To clear a set password, just press <Enter> when you are prompted to enter the password. A message will show up confirming the password will be disabled. Once the password is disabled, the system will boot and you can enter Setup without entering any password.

When a password has been set, you will be prompted to enter it every time you try to enter Setup. This prevents an unauthorized person from changing any part of your system configuration.

CELL MENU

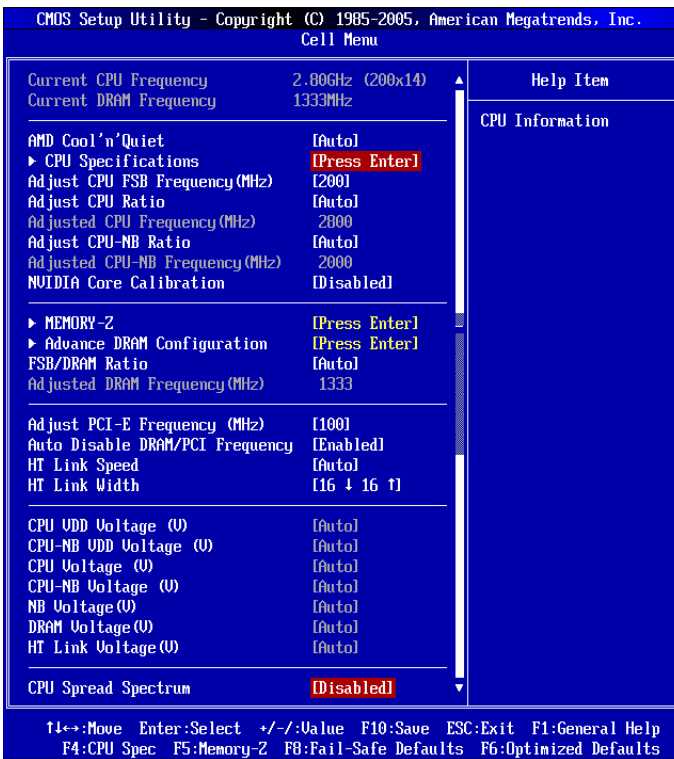

Important

Change these settings only if you are familiar with the chipset.

▶ Current CPU / DRAM Frequency

These items show the current clocks of CPU and Memory speed. Read-only.

▶ AMD Cool'n'Quiet

The Cool'n'Quiet technology can effectively and dynamically lower CPU speed and power consumption.

Important

To ensure that Cool'n'Quiet function is activated and will be working properly, it is required to double confirm that:

- Run BIOS Setup, and select Cell Menu. Under Cell Menu, find AMD Cool'n'Quiet, and set this item to "Enabled".
- Enter Windows, and select [Start]->[Settings]->[Control Panel]->[Power Options].

Enter *Power Options Properties* tag, and select *Minimal Power Management* under *Power schemes*, as shown below.

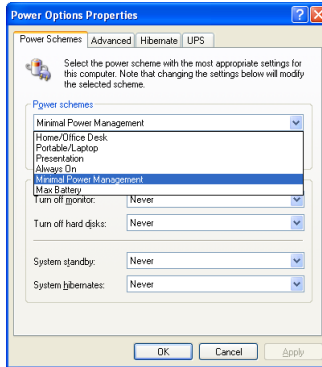

► **CPU Specifications**

Press <Enter> to enter the sub-menu and the following screen appears. This submenu shows the information of installed CPU.

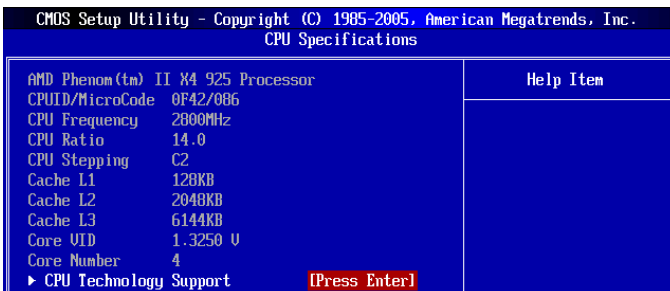

► **CPU Technology Support**

Press <Enter> to enter the sub-menu and the following screen appears. This submenu shows the technologies that the installed CPU supported.

► **Adjust CPU FSB Frequency (MHz)**

This item allows you to select the CPU Front Side Bus clock frequency (in MHz).

► **Adjust CPU Ratio**

This item is used to adjust CPU clock multiplier (ratio). It is available only when the processor supports this function.

► **Adjusted CPU Frequency (MHz)**

It shows the adjusted CPU frequency. Read-only.

► **Adjust CPU-NB Ratio**

This item is used to adjust CPU-NB ratio.

► **Adjusted CPU-NB Frequency (MHz)**

It shows the adjusted CPU-NB frequency. Read-only.

► NVIDIA Core Calibration

This item is for overclock. Setting to [Enabled] allows you to set the CPU Ratio higher. It is available only when the processor supports this function.

► Memory-Z

Press <Enter> to enter the sub-menu and the following screen appears.

CMOS Setup Utility - Copyright (C) 1985-2005, American Megatrends, Inc.	
MEMORY-Z	
► DIMM2 Memory SPD Information	[Press Enter]
	Help Item

► DIMM1~4 Memory SPD Information

Press <Enter> to enter the sub-menu and the following screen appears. This sub-menu displays the information of installed memory.

CMOS Setup Utility - Copyright (C) 1985-2005, American Megatrends, Inc.	
DIMM4 Memory SPD Information	
DIMM4 Memory SPD Information	Help Item
Memory Type: DDR2 SDRAM	
Manufacture: Manya	
Part Number: NT1GT64U8HA1BY-3C	
Serial Number: A24B754	
Memory CAS Latency Support:5	
SDRAM CYCLE TIME:3.0ns	
MEMORY TRCD: 15.0ns (5CLK)	
MEMORY TRP: 15.0ns (5CLK)	
MEMORY TRAS: 45ns (15CLK)	
MEMORY TRFC: 60.0ns (20CLK)	
MEMORY tWR: 15.0ns (5CLK)	
MEMORY tWTR: 7.50ns (2CLK)	
MEMORY TRRD: 7.50ns (2CLK)	
MEMORY TRTP: 7.50ns (2CLK)	

► Advance DRAM Configuration

Press <Enter> to enter the sub-menu and the following screen appears.

CMOS Setup Utility - Copyright (C) 1985-2005, American Megatrends, Inc.	
Advance DRAM Configuration	
DRAM Timing Mode	[DCT 0]
CAS Latency (CL)	[Auto]
tRCD	[Auto]
tRP	[Auto]
tRAS	[Auto]
tRTP	[Auto]
tRC	[Auto]
tWR	[Auto]
tRRD	[Auto]
tWTR	[Auto]
tRFC0	[Auto]
tRFC1	[Auto]
tRFC2	[Auto]
tRFC3	[Auto]
1T/2T Memory Timing	[ZT]
DCT Unganged Mode	[Enabled]
	Help Item
	When you change this item to Auto, system will read the data inside SPD "Serial Presence Detect" and run suitable memory timing setting. If you change this item to Both or others, then you can setup special memory timing. Normally you can see numbers 3-3-3-10 at sticker of module and

▶ DRAM Timing Mode

This field has the capacity to automatically detect all of the DRAM timing. If you set this field to [DCT 0], [DCT 1] or [Both], some fields will appear and selectable. DCT 0 controls channel A and DCT1 controls channel B.

▶ CAS Latency (CL)

When the DRAM Timing Mode sets to [DCT 0], [DCT1] or [Both], the field is adjustable. This controls the CAS latency, which determines the timing delay (in clock cycles) before SDRAM starts a read command after receiving it.

▶ tRCD

When the DRAM Timing Mode sets to [DCT 0], [DCT1] or [Both], the field is adjustable. When DRAM is refreshed, both rows and columns are addressed separately. This setup item allows you to determine the timing of the transition from RAS (row address strobe) to CAS (column address strobe). The less the clock cycles, the faster the DRAM performance.

▶ tRP

When the DRAM Timing Mode sets to [DCT 0], [DCT1] or [Both], the field is adjustable. This setting controls the number of cycles for Row Address Strobe (RAS) to be allowed to precharge. If insufficient time is allowed for the RAS to accumulate its charge before DRAM refresh may be incomplete and DRAM may fail to retain data. This item applies only when synchronous DRAM is installed in the system.

▶ tRAS

When the DRAM Timing Mode sets to [DCT 0], [DCT1] or [Both], the field is adjustable. This setting determines the time RAS takes to read from and write to a memory cell.

▶ tRTP

When the DRAM Timing Mode sets to [DCT 0], [DCT1] or [Both], the field is adjustable. This setting controls the time interval between a read and a precharge command.

▶ tRC

When the DRAM Timing Mode sets to [DCT 0], [DCT1] or [Both], the field is adjustable. The row cycle time determines the minimum number of clock cycles a memory row takes to complete a full cycle, from row activation up to the precharging of the active row.

▶ tWR

When the DRAM Timing Mode sets to [DCT 0], [DCT1] or [Both], the field is adjustable. It specifies the amount of delay (in clock cycles) that must elapse after the completion of a valid write operation, before an active bank can be precharged. This delay is required to guarantee that data in the write buffers can be written to the memory cells before precharge occurs.

▶ tRRD

When the DRAM Timing Mode sets to [DCT 0], [DCT1] or [Both], the field is adjustable. Specifies the active-to-active delay of different banks.

▶ tWTR

When the DRAM Timing Mode sets to [DCT 0], [DCT1] or [Both], the field is adjustable. This item controls the Write Data In to Read Command Delay memory timing.

This constitutes the minimum number of clock cycles that must occur between the last valid write operation and the next read command to the same internal bank of the DDR device.

▶ **tRFC0~3**

When the DRAM Timing Mode sets to [DCT 0], [DCT1] or [Both], these fields are adjustable. These settings determine the time RFC take to read from and write to memory cells.

▶ **1T/2T Memory Timing**

When the DRAM Timing Mode sets to [DCT 0], [DCT1] or [Both], the field is adjustable. This field controls the SDRAM command rate. Selecting [1T] makes SDRAM signal controller to run at 1T (T=clock cycles) rate. Selecting [2T] makes SDRAM signal controller run at 2T rate.

▶ **DCT Unganged Mode**

This feature is used to Integrate two 64-bit DCTs into a 128-bit interface.

▶ **FSB/DRAM Ratio**

This item allows you to select the ratio of FSB/ DRAM.

▶ **Adjusted DRAM Frequency (MHz)**

It shows the adjusted Memory frequency. Read-only.

▶ **Adjust PCI-E Frequency (MHz)**

This field allows you to select the PCIE frequency (in MHz).

▶ **Auto Disable DIMM/PCI Frequency**

When set to [Enabled], the system will remove (turn off) clocks from empty DRAM/ PCI slots to minimize the electromagnetic interference (EMI).

▶ **HT Link Speed**

This item allows you to set the Hyper-Transport Link speed. Setting to [Auto], the system will detect the HT link speed automatically.

▶ **HT Link Width**

These items allow you to set the Hyper-Transport Link width. Setting to [Auto], the system will detect the HT link width automatically.

▶ **CPU VDD Voltage (V)/ CPU-NB VDD Voltage (V)/ CPU Voltage (V)/ CPU-NB Voltage (V)/ NB Voltage (V)/ DRAM Voltage (V)/ HT Link Voltage (V)**

These items are used to adjust the voltage of CPU, Memory and chipset.

▶ **Spread Spectrum**

When the mainboard's clock generator pulses, the extreme values (spikes) of the pulses create EMI (Electromagnetic Interference). The Spread Spectrum function reduces the EMI generated by modulating the pulses so that the spikes of the pulses are reduced to flatter curves. If you do not have any EMI problem, leave the setting at Disabled for optimal system stability and performance. But if you are plagued by EMI, set to Enabled for EMI reduction. Remember to disable Spread Spectrum if you are overclocking because even a slight jitter can introduce a temporary boost in clock speed which may just cause your overclocked processor to lock up.

Important

- *If you do not have any EMI problem, leave the setting at [Disabled] for optimal system stability and performance. But if you are plagued by EMI, select the value of Spread Spectrum for EMI reduction.*
- *The greater the Spread Spectrum value is, the greater the EMI is reduced, and the system will become less stable. For the most suitable Spread Spectrum value, please consult your local EMI regulation.*
- *Remember to disable Spread Spectrum if you are overclocking because even a slight jitter can introduce a temporary boost in clock speed which may just cause your overclocked processor to lock up.*

USER SETTINGS

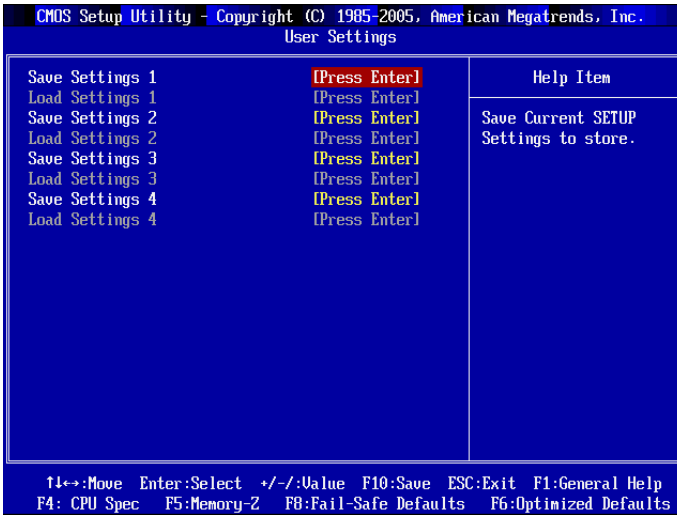

► Save Settings 1/ 2/ 3/ 4

These items are used to save the settings set by yourself to CMOS.

► Load Settings 1/ 2/ 3/ 4

These items are available after you save your settings in Save Settings 1/ 2/ 3/ 4 items, and are used to load the settings from CMOS.

Important

Failed Overclocking Resolution

This motherboard supports overclocking greatly. However, please make sure your peripherals and components are bearable for some special settings. Any operation that exceeds product specification is not recommended. Any risk or damage resulting from improper operation will not be under our product warranty.

Two ways to save your system from failed overclocking...

- **Reboot**

Press the Power button to reboot the system three times. Please note that, to avoid electric current to affect other devices or components, we suggest an interval of more than 10 seconds among the reboot actions.

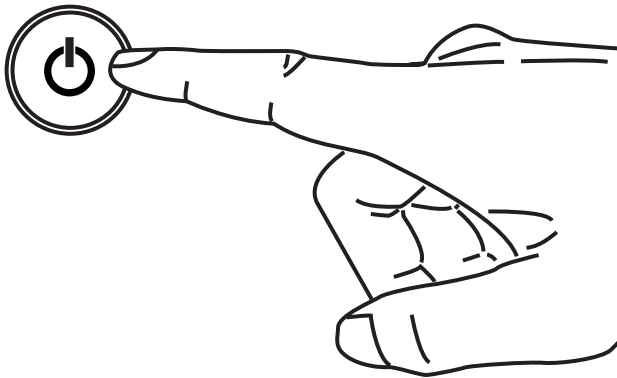

At the fourth reboot, BIOS will determine that the previous overclocking is failed and restore the default settings automatically. Please press any key to boot the system normally when the following message appears on screen.

**Warning !!! The previous overclocking had failed,
and system will restore its defaults setting,
Press any key to continue.....**

- **Clear CMOS**

Please refer to “Chapter 2” for more information about how to clear CMOS data.

LOAD FAIL-SAFE/ OPTIMIZED DEFAULTS

The two options on the main menu allow users to restore all of the BIOS settings to the default Fail-Safe or Optimized values. The Optimized Defaults are the default values set by the mainboard manufacturer specifically for optimal performance of the mainboard. The Fail-Safe Defaults are the default values set by the BIOS vendor for stable system performance.

When you select Load Fail-Safe Defaults, a message as below appears:



Selecting Ok and pressing Enter loads the BIOS default values for the most stable, minimal system performance.

When you select Load Optimized Defaults, a message as below appears:



Selecting Ok and pressing Enter loads the default factory settings for optimal system performance.

Appendix A

Realtek Audio

The Realtek audio provides 10-channel DAC that simultaneously supports 7.1 sound playback and 2 channels of independent stereo sound output (multiple streaming) through the Front-Out-Left and Front-Out-Right channels.

INSTALLING THE REALTEK HD AUDIO DRIVER

You need to install the HD audio driver for Realtek audio codec to function properly before you can get access to 2-, 4-, 6-, 8- channel or 7.1+2 channel audio operations. Follow the procedures described below to install the drivers for different operating systems.

Installation for Windows® XP

For Windows® XP, you must install Windows® XP Service Pack3 or later before installing the driver.

The following illustrations are based on Windows® XP environment and could look slightly different if you install the drivers in different operating systems.

1. Insert the application DVD into the DVD-ROM drive. The setup screen will automatically appear.
2. Click Realtek HD Audio Drivers button.



Important

The HD Audio Configuration software utility is under continuous update to enhance audio applications. Hence, the program screens shown here in this section may be slightly different from the latest software utility and shall be held for reference only.

3. Click Next to install the Realtek High Definition Audio Driver.

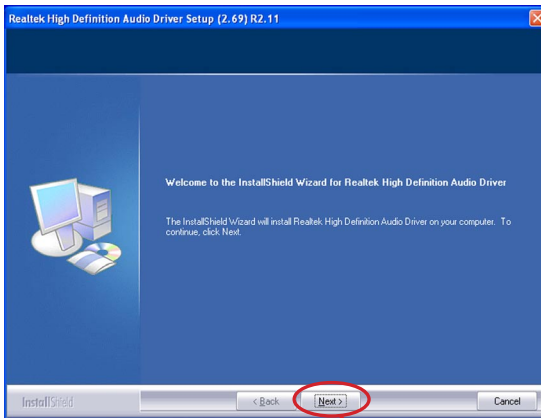

Click here

4. Click Finish to restart the system.

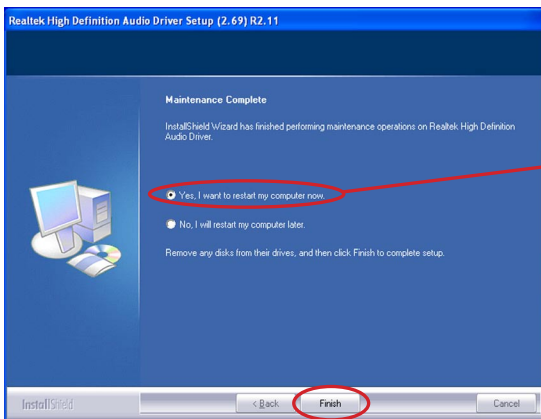

Select this option

Click here

SOFTWARE CONFIGURATION

After installing the audio driver, you are able to use the 2-, 4-, 6- or 8- channel audio feature now. Click the audio icon  from the system tray at the lower-right corner of the screen to activate the HD Audio Configuration. It is also available to enable the audio driver by clicking the **Realtek HD Audio Manager** from the Control Panel.

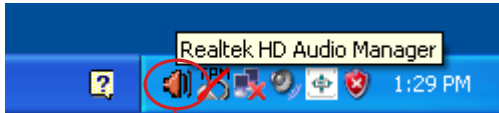

Double click

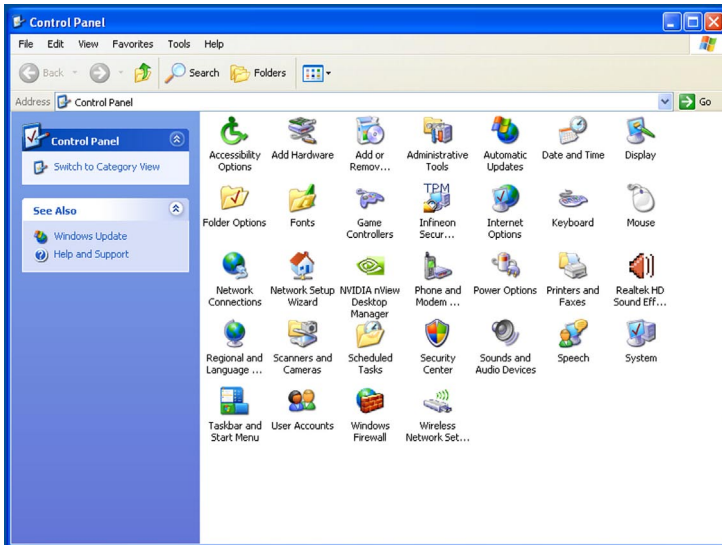

Sound Effect

Here you can select a sound effect you like from the **Environment** list.



Environment Simulation

You will be able to enjoy different sound experience by pulling down the arrow, totally 23 kinds of sound effect will be shown for selection. Realtek HD Audio Sound Manager also provides five popular settings “Stone Corridor”, “Bathroom”, “Sewer pipe”, “Arena” and “Auditorium” for quick enjoyment.

You may choose the provided sound effects, and the equalizer will adjust automatically. If you like, you may also load an equalizer setting or make an new equalizer setting to save as an new one by using the “Load EQ Setting” and “Save Preset” button, click “Reset EQ Setting” button to use the default value, or click “Delete EQ Setting” button to remove a preset EQ setting.

There are also other pre-set equalizer models for you to choose by clicking “Others” under the Equalizer part.

Equalizer Selection

Equalizer frees users from default settings; users may create their own preferred settings by utilizing this tool.

10 bands of equalizer, ranging from 100Hz to 16KHz.

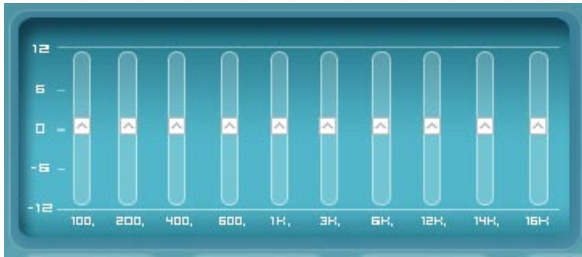

Save

The settings are saved permanently for future use

Reset

10 bands of equalizer would go back to the default setting

Enable / Disable

To disable, you can temporarily stop the sound effect without losing the settings

Load

Whenever you would like to use preload settings, simply click this, the whole list will be shown for your selection.

Delete

To delete the pre-saved settings which are created from previous steps.



Frequently Used Equalizer Setting

Realtek recognizes the needs that you might have. By leveraging our long experience at audio field, Realtek HD Audio Sound Manager provides you certain optimized equalizer settings that are frequently used for your quick enjoyment.

[How to Use It]

Other than the buttons “Pop”, “Live”, “Club” & “Rock” shown on the page, to pull down the arrow in “Others” you will find more optimized settings available to you.

Karaoke Mode

Karaoke mode brings Karaoke fun back home. Simply using the music you usually play, Karaoke mode can help you eliminate the vocal of the song or adjust the key to accommodate your range.

1. Vocal Cancellation: Single click on “Voice Cancellation” the vocal of the song would be eliminated, while the background music is still in place, and you can be that singer!
2. Key Adjustment: Using “Up / Down Arrow” to find a key which better fits your vocal range.

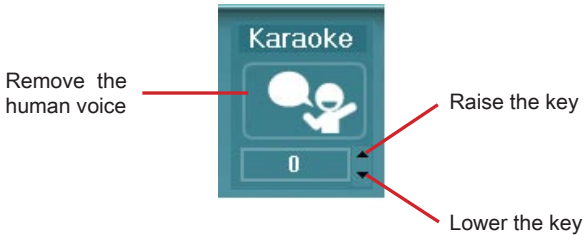

Mixer

In the Mixer part, you may adjust the volumes of the rear and front panels individually.

■ Adjust Volume

You can adjust the volume of the speakers that you plugged in front or rear panel by select the Realtek HD Audio rear output or Realtek HD Audio front output items.



Important

Before set up, please make sure the playback devices are well plugged in the jacks on the rear or front panel. The Realtek HD Audio front output item will appear after you plugging the speakers into the jacks on the front panel.

■ Multi-Stream Function

Realtek audio supports an outstanding feature called Multi-Stream, which means you may play different audio sources simultaneously and let them output respectively from the indicated real panel or front panel. This feature is very helpful when 2 people are using the same computer together for different purposes.

Click the  button and the Mixer ToolBox menu will appear. Then check the Enable playback multi-streaming and click OK to save the setup.

Important

You have to plug audio device into the jacks on the rear and front panel first before enable the multi-stream function.



When you are playing the first audio source (for example: use Windows Media Player to play DVD/VCD), the output will be played from the rear panel, which is the default setting.

Then you must to select the **Realtek HD Audio 2nd output** from the scroll list first, and use a different program to play the second audio source (for example: use Winamp to play MP3 files). You will find that the second audio source (MP3 music) will come out from the Line-Out audio jack of Front Panel.



■ Playback control



Tool Mute

Playback device

This function is to let you freely decide which ports to output the sound. And this is essential when multi-streaming playback enabled.

- Realtek HD Audio Rear Output
- Realtek HD Audio Front Output

Mute

You may choose to mute single or multiple volume controls or to completely mute sound output.

Tool

- Show the following volume controls

This is to let you freely decide which volume control items to be displayed.

- Advanced controls
- Enable playback multi-streaming

With this function, you will be able to have an audio chat with your friends via headphone (stream 1 from front panel) while still have music (stream 2 from back panel) in play. At any given period, you can have maximum 2 streams operating simultaneously.



■ Recording control



Mute

You may choose to mute single or multiple volume controls or to completely mute sound input.

Tool

- Show the following volume controls

This is to let you freely decide which volume control items to be displayed.

- Enable recording multi-streaming

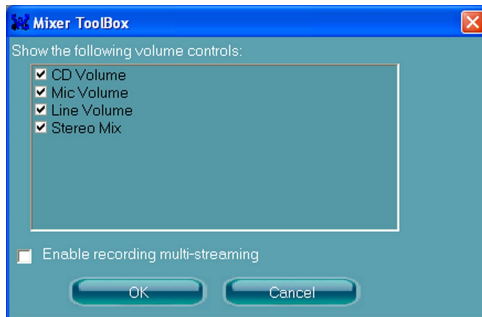

Important

Realtek audio allows you to record the CD, Line, Mic and Stereo Mix channels simultaneously, frees you from mixing efforts. At any given period, you may choose 1 of the following 4 channels to record.

Audio I/O

In this tab, you can easily configure your multi-channel audio function and speakers. You can choose a desired multi-channel operation here.

- **Headphone** for the common headphone
- **2CH Speaker** for Stereo-Speaker Output
- **4CH Speaker** for 4-Speaker Output
- **6CH Speaker** for 5.1-Speaker Output
- **8CH Speaker** for 7.1-Speaker Output

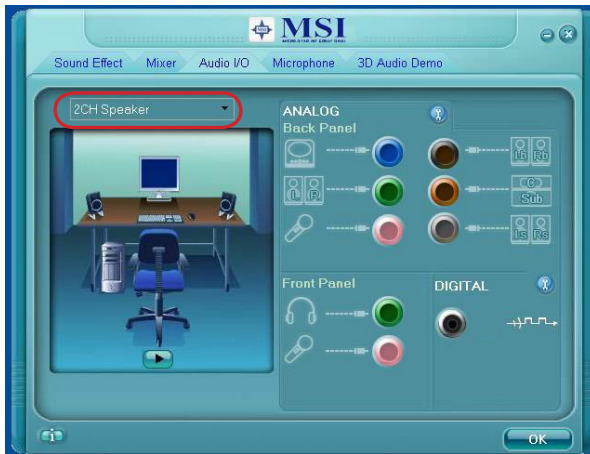

■ Speaker Configuration:

1. Plug the speakers in the corresponding jack.
2. Dialogue “connected device” will pop up for your selection. Please select the device you have plugged in.
 - If the device is being plugged into the correct jack, you will be able to find the icon beside the jack changed to the one that is same as your device.
 - If not correct, Realtek HD Audio Manager will guide you to plug the device into the correct jack.

■ Connector Settings

Click  to access connector settings.



Disable front panel jack detection (optional)

Jack detection function only works with HD audio front panel. Please check if front jacks on your system are so-called AC'97 jacks. If so, please check this item to disable front panel jack detection.

Mute rear panel output when front headphone plugged in.

Enable auto popup dialogue, when device has been plugged in

Once this item checked, the dialog "Connected device" would automatically pop up when device plugged in.

S/PDIF

Short for Sony/Philips Digital Interface, a standard audio file transfer format. S/PDIF allows the transfer of digital audio signals from one device to another without having to be converted first to an analog format. Maintaining the viability of a digital signal prevents the quality of the signal from degrading when it is converted to analog.

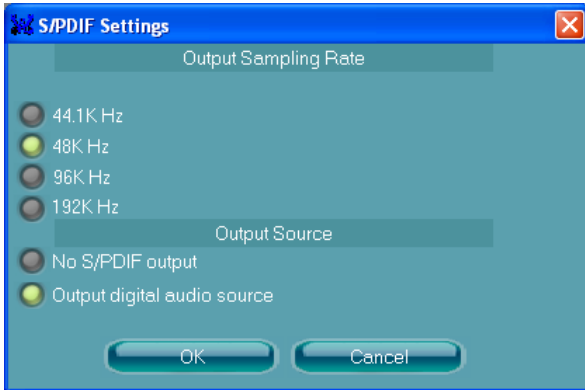

Output Sampling Rate

44.1KHz: This is recommend while playing CD.

48KHz: This is recommended while playing DVD or Dolby.

96KHz: This is recommended while playing DVD-Audio.

192KHz: This is recommended while playing High quality Audio.

Output Source

Output digital audio source: The digital audio format (such as .wav, .mp3, .midi etc) will come out through S/PDIF-Out.

S/PDIF-in to S/PDIF -out pass though mode: The data from S/PDIF-In can be real-time played from S/PDIF-Out.

Test Speakers

You can select the speaker by clicking it to test its functionality. The one you select will light up and make testing sound. If any speaker fails to make sound, then check whether the cable is inserted firmly to the connector or replace the bad speakers with good ones. Or you may click the **auto test**  button to test the sounds of each speaker automatically.

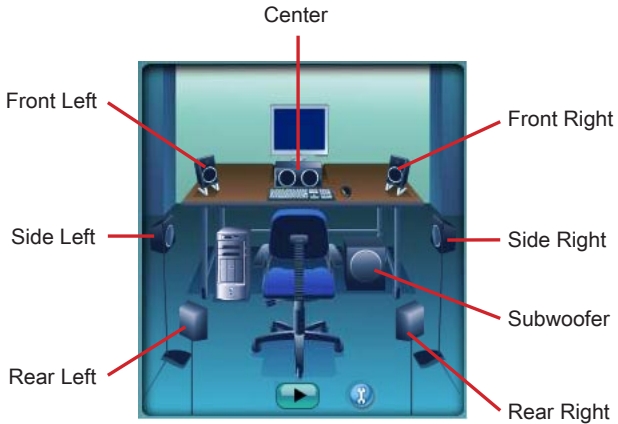

Microphone

In this tab you may set the function of the microphone. Select the **Noise Suppression** to remove the possible noise during recording, or select **Acoustic Echo Cancellation** to cancel the acoustic echo during recording.

Acoustic Echo Cancellation prevents playback sound from being recorded by microphone together with your sound. For example, you might have chance to use VOIP function through Internet with your friends. The voice of your friend will come out from speakers (playback). However, the voice of your friend might also be recorded into your microphone then go back to your friend through Internet. In that case, your friend will hear his/her own voice again. With AEC(Acoustic Echo Cancellation) enabled at your side, your friend can enjoy the benefit with less echo.



3D Audio Demo

In this tab you may adjust your 3D positional audio before playing 3D audio applications like gaming. You may also select different environment to choose the most suitable environment you like.



Information

In this tab it provides some information about this HD Audio Configuration utility, including Audio Driver Version, DirectX Version, Audio Controller & Audio Codec. You may also select the language of this utility by choosing from the **Language** list.



Also there is a selection **Show icon in system tray**. Switch it on and an icon  will show in the system tray. Right-click on the icon and the **Audio Accessories** dialogue box will appear which provides several multimedia features for you to take advantage of.



HARDWARE SETUP

Connecting the Speakers

When you have set the Multi-Channel Audio Function mode properly in the software utility, connect your speakers to the correct phone jacks in accordance with the setting in software utility.

- 2-Channel Mode for Stereo-Speaker Output

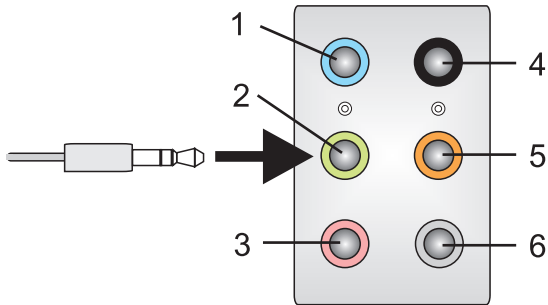

- 1] Line In
- 2] Line Out (Front channels)
- 3] MIC
- 4] No function
- 5] No function
- 6] No function

■ 4-Channel Mode for Stereo-Speaker Output

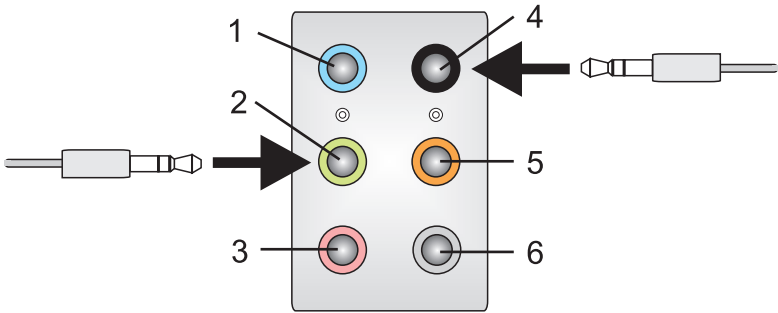

- 1] Line In
- 2] Line Out (Front channels)
- 3] MIC
- 4] Line Out (Rear channels)
- 5] No function
- 6] No function

■ 6-Channel Mode for Stereo-Speaker Output

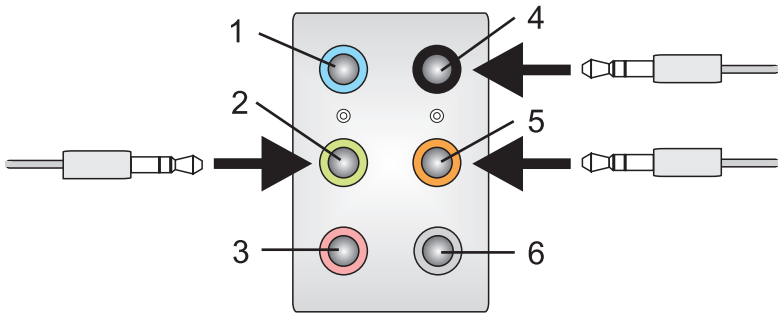

- 1] Line In
- 2] Line Out (Front channels)
- 3] MIC
- 4] Line Out (Rear channels)
- 5] Line Out (Center and Subwoofer channel)
- 6] No function

■ 8-Channel Mode for Stereo-Speaker Output

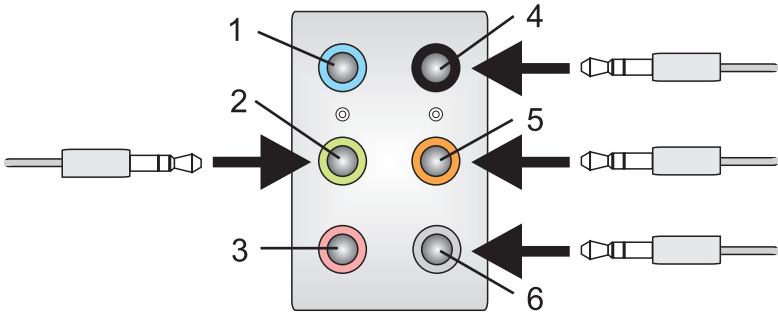

- 1] Line In
- 2] Line Out (Front channels)
- 3] MIC
- 4] Line Out (Rear channels)
- 5] Line Out (Center and Subwoofer channel)
- 6] Line Out (Side channels)

Important

To enable 7.1 channel audio-out function on Vista operating system, you have to install the Realtek Audio Driver. Or, the mainboard will support 5.1 channel audio-out only.

Appendix B

NVIDIA RAID

NVIDIA brings Redundant Array of Independent Disks (RAID) technology-which is used by the world's leading businesses-to the common PC desktop. This technology uses multiple drives to either increase total disk space or to offer data protection. For all levels, RAID techniques optimize storage solutions by using multiple disks grouped together and treating them as a single storage resource.

INTRODUCTION

System Requirement

Operating System Support

NVRAID supports the following operating systems:

Windows XP, Windows Vista

RAID Arrays

NVRAID supports the following types of RAID arrays described in this section:

- RAID 0: RAID 0 defines a disk striping scheme that improves the disk read and write times for many applications.
- RAID 1: RAID 1 defines techniques for mirroring data.
- RAID 0+1: RAID 0+1 combines the techniques used in RAID 0 and RAID 1 arrays.
- RAID 5: RAID 5 defines techniques for parity data.
- Spanning (JBOD): JBOD provides a method for combining drives of different sizes into one large disk

Summary of RAID Configurations

Array	Uses	Advantages	Drawbacks	#Hard Disks	Fault Tolerance
RAID 0	Non-critical data requiring high performance.	High data throughput.	No fault tolerance.	multiple	None
RAID 1	Small databases or any other small capacity environment requiring fault tolerance.	100% data redundancy.	Requires 2 drives for the storage space of 1 drive.	2	Yes
RAID 0+1	Critical data requiring high performance.	Optimized for both 100% data redundancy and performance. Allow spare disks.	Requires 2 drives for the storage space of 1 drive - the same as RAID level 1.	4+	Yes
RAID 5	Critical data and reasonable level of performance.	Fault tolerance and better utilization of disk space.	Decreased write performance due to parity calculations. Requires at least three drives.	3+	Yes
JBOD	Combining odd size drives into one big drive.	Combines and used the capacity of odd size drives.	Decreases performance because of the difficulty in using drives concurrently or to optimize drives for different uses	Multiple	No

RAID CONFIGURATION

Basic Configuration Instructions

The following are the basic steps for configuring NVRAID:

Non-Bootable RAID Array

1. Choose the hard disks that are to be RAID enabled in the system BIOS. (Refer the BIOS section for details.)
2. Specify the RAID level, either Mirroring (RAID 1), Striping (RAID 0), Striping and Mirroring (RAID 0+1), RAID 5 or JBOD and create the desired RAID array.
3. Enter the Windows OS, run the Windows nForce Setup application and install the RAID software. (Check p.B-8 for details.)
4. Initialize the NVRAID Array Disks.

Bootable RAID Array

1. Choose the hard disks that are to be RAID enabled in the system BIOS.(Refer the bios section for details.)
2. Specify the RAID level, either Mirroring (RAID 1), Striping (RAID 0), Striping and Mirroring (RAID 0+1), RAID 5 or JBOD and create the desired RAID array.
3. Boot from the Windows CD, use the floppy disk that has the RAID driver to copy and install the nForce RAID software. (Check p.B-7 for details.)
4. Initialize the NVRAID Array Disks.

Setting Up the NVRAID BIOS

Be sure to enable the **RAID** function in BIOS before configuring the NVRAID BIOS. After that press F10 to save the configuration and exit. The PC will reboot right away. Then enter the RAID BIOS Setup by pressing **F10** when prompted, and follow the procedures described below to set up the NVRAID BIOS.

NVRAID BIOS setup lets you choose the RAID array type and which hard drives you want to make part of the array.

Entering the RAID BIOS Setup

1. After rebooting your PC, wait until you see the RAID software prompting you to press **F10**. The RAID prompt appears as part of the system POST and boot process prior to loading the OS.
2. Press **F10**, and the press **N**, the NVIDIA RAID Utility **Define a New Array** window will appear. The default **RAID Mode** is set to **Mirroring** and **Stripe Block** is set to **Optimal**.

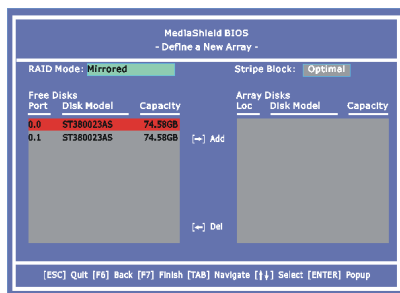

Understanding the "Define a New Array" Window

Use the Define a New Array window to

- Select the RAID Mode
- Set up the Striping Block
- Specify which disks to use for the RAID Array

The SATA ports are called channels and they are associated with adapters. The first digit in the Location field defines the adapter that the port is associated with. The 2nd digit defines the channel.

Adapter ← 0.1 → Channel

In the example above, 0.1 means the hard drive is attached to Adapter 0, Channel 1. The following is a reference list of some possible combinations:

Serial ATA

0.0	Adapter 0, Channel 0 (SATA1)
0.1	Adapter 0, Channel 1 (SATA2)
0.2	Adapter 0, Channel 3 (SATA3)
0.3	Adapter 0, Channel 4 (SATA4)
	...
	...

Important

There is no such thing as Slave drive in Serial ATA. All drives are considered to be Master since there is a one to one connection between the drive and the controller.

Using the Define a New Array Window

If necessary, press the tab key to move from field to field until the appropriate field is highlighted.

■ Selecting the RAID Mode

By default, this is set to [Mirroring]. To change to a different RAID mode, press the down arrow key until the mode that you want appears in the RAID Mode box- either [Mirroring], [Stripe], [RAID5], [Spanning], or [Stripe Mirroring].

■ Selecting the Striping Block Size

Striping Block size is given in kilobytes, and affects how data is arranged on the disk. It is recommended to leave this value at the default [Optimal], which is 32KB, but the values can be between [4 KB] and [128 KB].

■ Assigning the Disks

Any disks in your system that are not part of a RAID array appear in the Free Disks block. These are the drives that are available for use as RAID array disks.

To designate a free disk to be used as a RAID array disk,

1. Tab to the Free Disks section. The first disk in the list is selected.
2. Move it from the **Free Disks** block to the Array Disks block by pressing the right arrow key (→). The first disk in the list is moved, and the next disk in the list is selected and ready to be moved.
3. Continue pressing the right-arrow key (→) until all the disks that you want to use as RAID array disks appear in the **Array Disks** block.

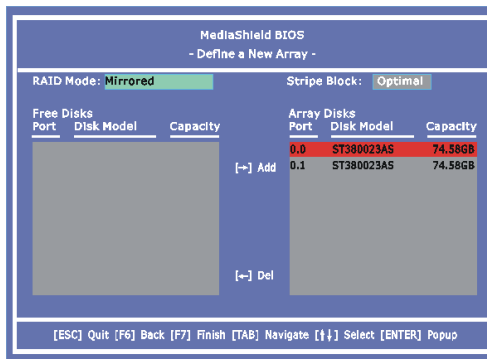

It shows that two disks have been assigned as RAID1 array disks in the figure above.

Completing the RAID BIOS Setup

- After assigning your RAID array disks, press **F7**. The Clear disk data / Clear MBR prompt appears.

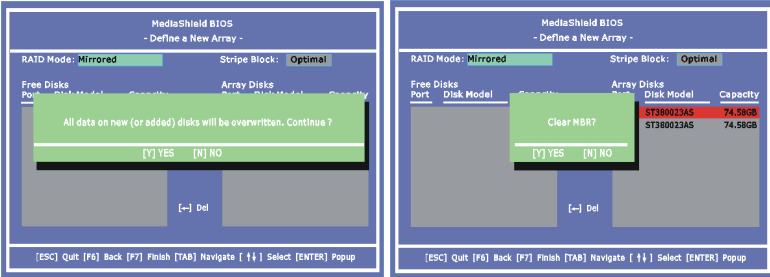

- Press **Y** to clear the disk data / MBR. The Array List screen appears, where you can review the RAID arrays that you have set up.

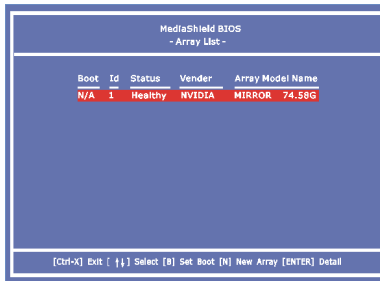

- Use the arrow keys to select the array that you want to set up, then press **Enter**. The **Array Detail** window appears.

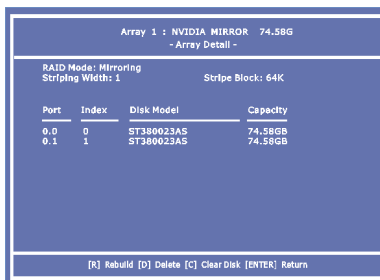

- The Array Detail screen shows various information about the array that you selected, such as Stripe Block, RAID Mode, Stripe Width, Disk Model Name, and disk capacity.
- Press **Enter** again to go back to the previous window and then press **F10** to exit the RAID setup. Now that the RAID setup has been configured from the RAID BIOS, the next step is to configure and load NVRAID drivers under Windows, as explained in "Installing the NVIDIA MediaShield Software Under Windows" on p.B-8.

INSTALLING DRIVER

Install Driver in Windows Vista / XP

■ New Windows Vista/ XP Installation

For Windows XP:

1. When you start installing Windows XP, you may encounter a message stating, "Setup could not determine the type of one or more mass storage devices installed in your system". If this is the case, then you are already in the right place and are ready to supply the driver. If this is not the case, then press F6 when prompted at the beginning of Windows setup.
2. Press the "S" key to select "Specify Additional Device".
3. You should be prompted to insert a floppy disk containing the NVIDIA RAID driver into the A: drive, and then press ENTER.

Important

Please follow the instruction below to make an "NVIDIA RAID Driver".

- a) Insert the MSI DVD into the DVD-ROM drive.
 - b) Click the "Browse DVD" on the Setup screen.
 - c) For Windows XP, copy all the contents in the
 \\ChipSet\\nVidia\\MCP\\XP\\IDE\\WinXP\\sataraid to a formatted floppy disk.
 For Windows XP, copy all the contents in the
 \\ChipSet\\nVidia\\MCP\\VISTA\\IDE\\WinVista\\sataraid to a medium (floppy disk/
 CD/DVD or USB).
 - d) The driver diskette for NVIDIA RAID Controller is done.
4. You should be shown a list of available NVRAID Adapters.
 5. Select the "NVIDIA RAID Driver" and press ENTER.
 6. Press "S" again at the Specify Devices screen, then press ENTER.
 7. Select "NVIDIA NForce Storage Controller" and then press ENTER.
 8. Press **Enter** to continue with Windows XP Installation. Be sure to leave the floppy disk inserted in the floppy drive until the blue screen portion of Windows XP installation is completed, then take out the floppy.
 9. Follow the instructions on how to install Windows XP. After Windows XP is completely installed, it is recommended that you install the the RAID management tool.

For Windows Vista:

During the operating system installation, after selecting the location to install Windows Vista, please click on the "Load Driver" button to load RAID driver. Please refer the Important notice above to make a RAID Driver medium. And then, follow the instructions to complete the whole installation.

Notice: Each time you add a new hard drive to a RAID array, the RAID driver will have to be installed under Windows once for that hard drive. After that, the driver will not have to be installed.

NVIDIA RAID UTILITY INSTALLATION

Installing the NVIDIA MediaShield Software Under Windows (for Non-bootable RAID Array)

The existing Windows Serial ATA driver must be upgraded to use the NVIDIA Serial ATA driver.

This section describes how to run the setup application and install the RAID software which will upgrade the Windows SATA driver and install the RAID software.

1. Start the nForce Setup program to open the NVIDIA Windows nForce Drivers page.

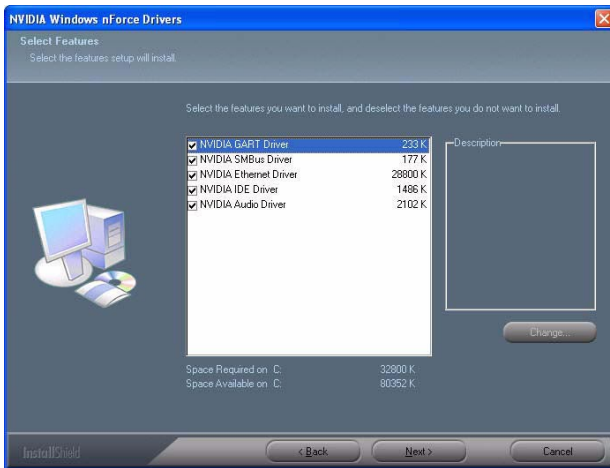

2. Select the modules that you want to install.

Important

Make sure that the "NVIDIA IDE Driver" is selected. You must install the NVIDIA IDE driver in order to enable NVIDIA MediaShield. If you do not install the NVIDIA IDE driver, NVIDIA MediaShield will not be enabled.

3. Click Next and then follow the instructions.
4. After the installation is completed, be sure to reboot the PC.
5. After the reboot, initialize the newly created array as described in the next section.

Initializing and Using the Disk Array

The RAID array is now ready to be initialized under Windows.

1. Launch Computer Management by clicking “Start” → “Settings” → “Control Panel” then open the “Administrative Tools” folder and double click on “Computer Management”.
2. Click “Disk Management” (under the “Storage” section). The Initialize and Convert Disk Wizards appears.

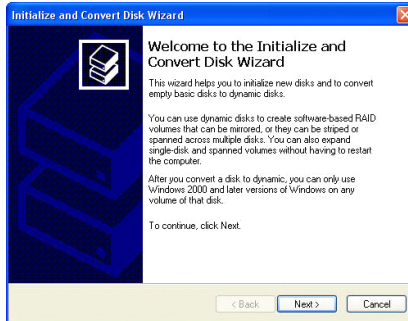

3. Click Next. The Select Disks to Initialize window appears. The disks listed depend on how many arrays you have configured.

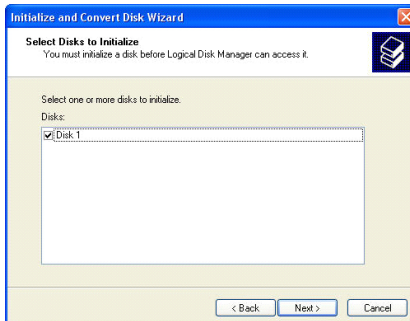

4. Click Next. The Select Disks to Convert window appears.

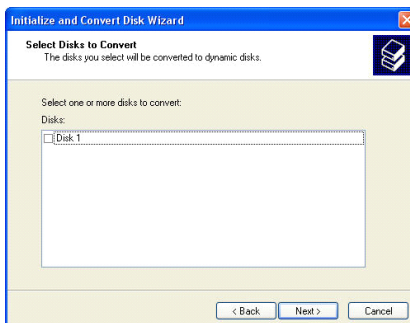

- Check the disk in the list if you want to make the array a dynamic disk, then click Next. The Completing the Initialize and Convert Disk Wizard window appears.

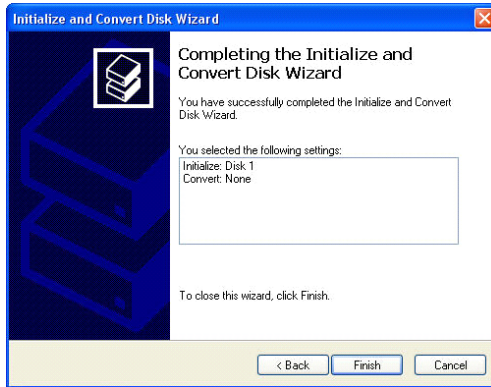

- Click Finish. The "Computer Management" window appears.

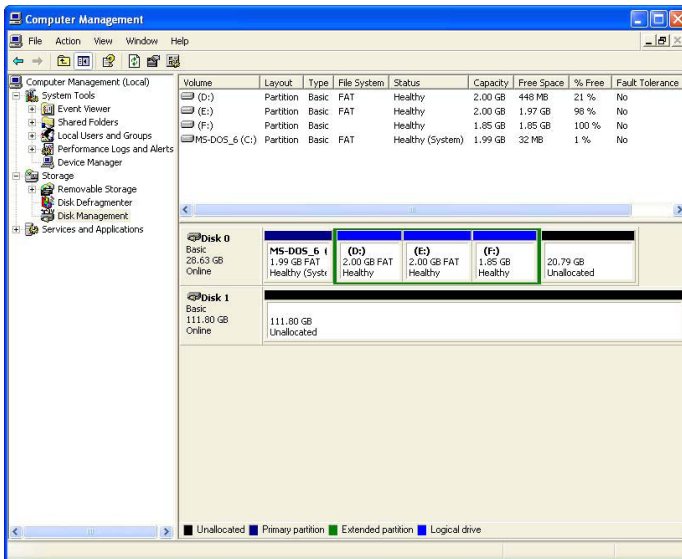

The actual disks listed will depend on your system, and the unallocated partition is the total combined storage of two hard disks. You must format the unallocated disk space in order to use it.

- Format the unallocated disk space. Right click "Unallocated space" select "New Partition..." and follow the wizard. After the drive has been formatted, it is ready for use.

USING THE NVMEDIA SHIELD SOFTWARE

Accessing the Storage Page

To access the NVIDIA Control Panel Storage page:

1. Click Start-> Programs-> NVIDIA Corporation-> NVIDIA Control Panel-> Storage.

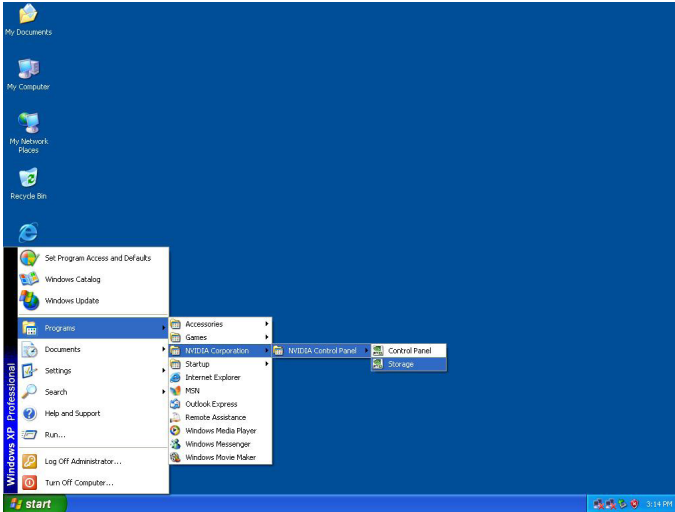

2. The NVIDIA Control Panel - Storage page appears.

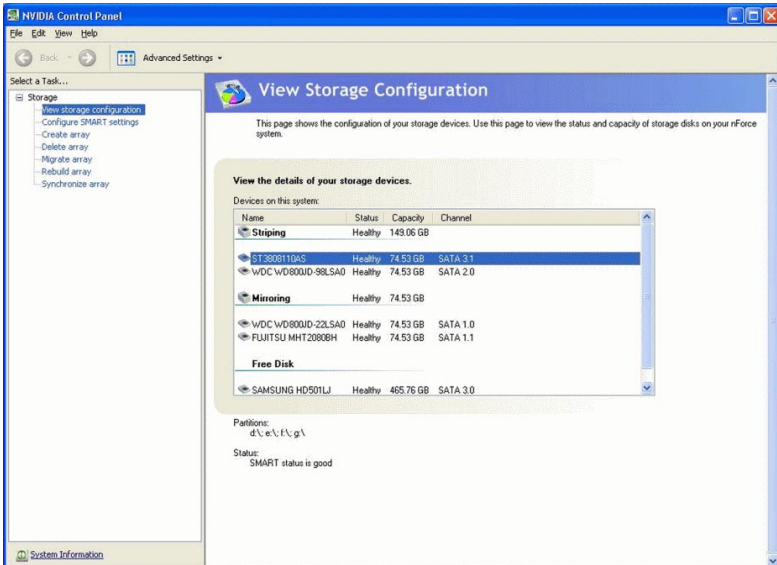

Using the Storage Page

From the Storage page, you can accomplish the following tasks:

- Create an Array
- Delete an Array
- Rebuild an Array
- Synchronize an Array
- Designate a Spare Disk
- Remove a Spare
- Migrate an Array
- Using the SMART Disk Feature

Create an Array

This option is available only if there are free disks that are RAID-enabled.

Click **Create array** to start the Create Array Wizard and then follow the instructions.

You can press **F1** to access the online help that walks you through the Wizard with step-by-step instructions.

Delete an Array

This option is available only if RAID arrays have been created.

Click **Delete array** to start the Delete Array Wizard and then follow instructions.

You can press **F1** to access the online help that walks you through the Wizard with step-by-step instructions.

Rebuild an Array

About Rebuilding

Rebuilding is the process of restoring data to a hard drive from other drives in the array. For example, if you have a three disk RAID 5 array and one of the drives fails, you will need to replace the failed drive with a new one, and rebuild the array to re-generate the lost data on the newly added drive.

Rebuilding applies only to fault-tolerant arrays such as RAID 1, RAID 0+1, or RAID 5 Arrays.

Instructions

Click **Rebuild array** to start the Rebuild Create Array Wizard and then follow the instructions.

You can press **F1** to access the online help that walks you through the Wizard with step-by-step instructions.

The rebuilding process takes some time to complete, and occurs in the background so as not to affect the performance of the system.

Synchronize an Array

Synchronizing an array will force a rebuild of redundancy or parity. The operation applies to any fault-tolerant array such as RAID 1, 0+1 and RAID 5.

Click **Synchronize array** to start the Synchronize Array Wizard and then follow instructions.

You can press **F1** to access the online help that walks you through the Wizard with step-by-step instructions.

Designate a Spare Disk

About Spare Disks

You can designate a hard drive to be used as a spare drive for a RAID 1, RAID 0+1 or RAID 5 array. The spare drive can take over for a failed disk. MediaShield RAID supports two types of spare drives:

Free Disk

A free disk is a disk that is not part of any RAID array, but can be used by any available RAID 1, RAID 0+1, or RAID 5 array that requires another disk when one of its disks crashes or becomes unusable. The process is automatic and requires no user interaction.

Example: A system may have four hard disks where one disk is used to boot the OS, two hard drives are set up in a mirrored array, and a fourth hard disk is set up as a free disk. If one of the mirrored array drives fails, the free disk will be assigned automatically to the mirrored array to replace the failed disk.

Dedicated Disk

A dedicated free disk is a disk that is assigned to a RAID 1, RAID 0+1, or RAID 5 array. The dedicated disk is used by that array only when needed - for example, during a system crash where a RAID mirrored drive is broken. The dedicated disk can be used only by the array that it is assigned to and not by any other array, unlike a free disk which can be used by any available RAID 1, RAID 0+1, or RAID 5 array.

To mark a disk as dedicated (reserve it for use by a specific array), you must have at least one free disk and you must also have at least two RAID 1, RAID 0+1, or RAID 5 arrays created.

Requirements for Designating a Spare Disk

The Designate Spare option on the Storage page appears only if all the following conditions are met.

- There must be at least two fault tolerant arrays already created.
- There must be at least one free disk with capacity equal to or greater than the smallest disk in the given fault tolerant array.

For example, if a mirror array is created with disk capacities of 40 GB and 80 GB, there should be at least one free disk available of capacity equal to or greater than 40GB to be used as a spare disk for that array.

Instructions

Click Designate spare to start the Designate Spare Wizard and then follow instructions.

You can press **F1** to access the online help that walks you through the Wizard with step-by-step instructions.

Remove a Spare

The Remove spare option appears only if you have a RAID array with a spare disk allocated to it.

Click Remove spare to start the Remove Spare Wizard and then follow the instructions.

You can press **F1** to access the online help that walks you through the Wizard with step-by-step instructions.

Migrate an Array

In a traditional RAID environment, when a user wants to change the current state of a disk or a current array to a new RAID configuration, the process of reconfiguring the new array involves multiple steps. The user must back up the data, delete the array, re-boot the PC, and then reconfigure the new array.

MediaShield RAID allows the end user to change the current state of the disk or array to another with a one-step process called "Migrating". This section describes the NVIDIA Migrating process and explains how to use Migrating to convert from one RAID array type to another.

General Migrating Requirements

- The new array capacity must be equal to or greater than the previous array.
For example, it is possible to migrate from a RAID 1 array to a RAID 0 array as long as the RAID 0 array is the same size as (or larger than) the RAID 1 array.
- The number of disks in the new array cannot be less than the number of disks in the original array.
- You cannot migrate
 - To or from a JBOD (Spanning) array
 - From RAID 1 to RAID 1
 - From RAID 0+1 to RAID 1
 - From RAID 5 to 1

Migrating to an Array Larger Than 2 TB

Your disks must be partitioned using the GUID partition table (GPT) if you plan to migrate to an array with greater than 2 TB storage.

If your original array is not a GPT disk and you expand your array's capacity using the migration feature to over 2 TB, you will not be able to access the additional storage above 2 TB in the new array. To use the additional storage in this situation, back up your data, repartition the array using GPT, then restore your data to the new volume.

Important

Be sure to make the volume dynamic if you plan to have more than four partitions.

Specific Migrating Requirements

The following table lists the disk requirements for a new RAID array for various migrating combinations.

From	To	New Array Disk Requirements
RAID 0	RAID 0	$m > n$ Number of disk in the new array must be greater than the original array.
	RAID 1	$m = 2, n = 1$ RAID 1 array must include two disks, converted from a one disk RAID 0 array.
	RAID 0+1	$m \geq 2 \times n$ Number of RAID 0+1 disks must be equal to or greater than twice the number of RAID 0 disks.
	RAID 5	$m \geq n+1$
RAID 1	RAID 0	No additional restrictions.
	RAID 1	** Not a valid combination **
	RAID 0+1	No additional restrictions.
	RAID 5	$m \geq 3$
RAID 0+1	RAID 0	$m \geq n/2$ Number of RAID 0 disks must be equal to or greater than half the number of RAID 0+1 disks.
	RAID 1	** Not a valid combination **
	RAID 0+1	** Not a valid combination **
	RAID 5	$m \geq (n/2 + 1)$
RAID 5	RAID 0	$m \geq n - 1$
	RAID 1	** Not a valid combination **
	RAID 0+1	$m \geq 2 \times (n-1)$; where m is an even number of disks.
	RAID 5	$m \geq n$

Instructions

Click Migrate array to start the Migrate Array Wizard and then follow instructions.

You can press **F1** to access the online help that walks you through the Wizard with step-by-step instructions.

Using the SMART Disk Feature

S.M.A.R.T. stands for Self-Monitoring, Analysis, and Reporting Technology. It is a disk drive feature that allows software to monitor degradations in disk drive specifications. Using this technology, NVIDIA MediaShield lets you monitor the health of disk drives in a RAID array and alerts you when certain degradations indicate an impending hardware failure, giving you time to back up data and replace the drive. When you click on an array disk from the View Storage Configuration page, the SMART status appears, indicating whether (as of the last polling) the disk is healthy (good) or whether there is a problem that can result in a catastrophic failure within 24 hours.

To configure SMART settings:

1. Click Configure SMART settings to open the associated page. Select the Enable SMART monitoring radio button.

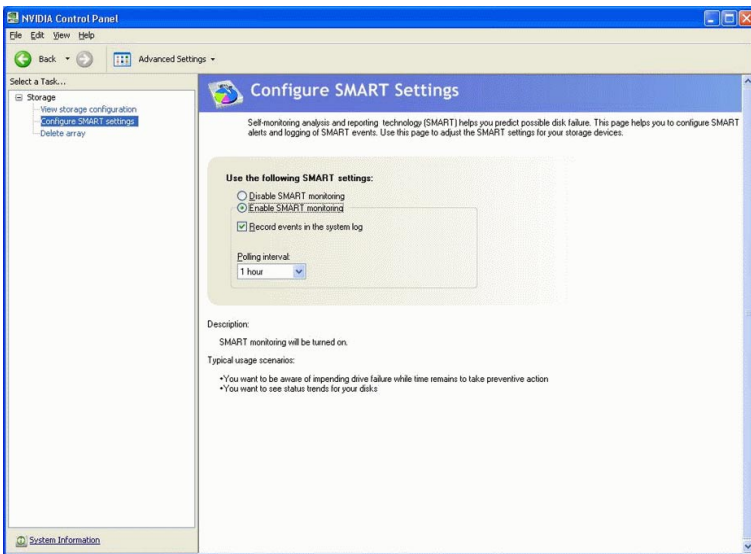

2. If you want to track the test results, check the Record events in the system log check box.
3. Click the Polling interval list arrow and then select one of the time options corresponding to how often you want MediaShield to run the SMART test.
4. Click Apply when done.

To view the SMART status:

1. Click View storage configuration to open the associated page.
2. Click on a disk from the list of array disks.

The SMART status, if available, appears in the STATUS notes section.

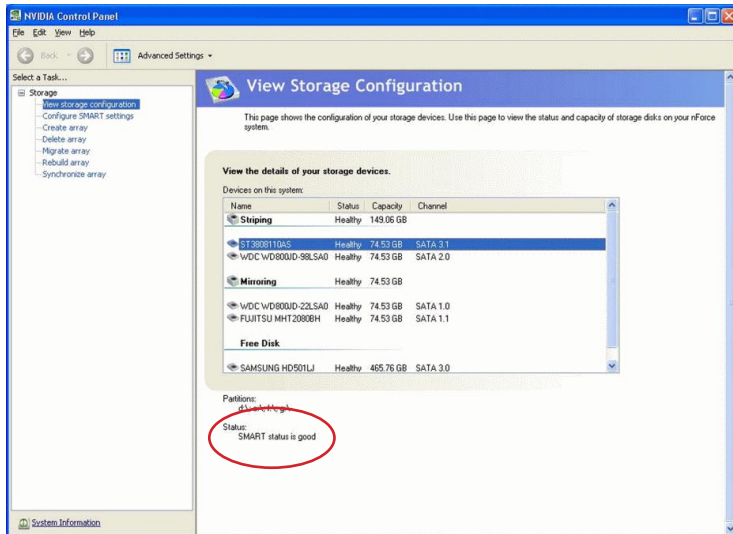

To view the SMART status event logs:

Windows XP

1. Open the Windows Control Panel.
2. Double-click Administrative Tools, then double-click Computer Management.
3. Under System Tools→Event Viewer→Windows Logs, click System.

The events are listed in the NVRAIDSERVICE Source entries.

Windows Vista

1. Open the Windows Control Panel.
2. Double-click Administrative Tools, then double-click Computer Management.
3. Under System Tools→Event Viewer→Windows Logs, click Application.

The events are listed in the NVRAIDSERVICE Source entries.

Appendix C

Overclocking Center

Overclocking Center, the most useful and powerful utility that MSI has spent much research and efforts to develop, helps users to monitor or configure the hardware status of MSI Mainboard in windows, such as CPU clock, voltage, fan speed and temperature.

Before you install the Overclocking Center, please make sure the system has meet the following requirements:

1. 256MB system memory.
2. DVD-ROM drive for software installation.
3. Operation system: Windows XP or up.
4. DotNet Frame Work 2.0

ACTIVATING OVERCLOCKING CENTER

Once you have your Overclocking Center installed (locate the setup source file in the setup CD accompanying with your mainboard, path: **Utility --> MSI Utility --> Overclocking Center**), it will have a short cut icon on the desktop, and a short cut path in your "Start-up" menu. You may double-click on each icon to activate Overclocking Center.

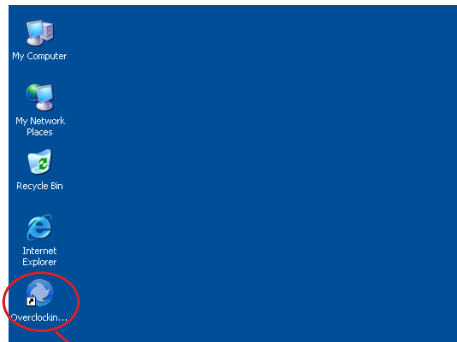

short-cut icon on the desktop

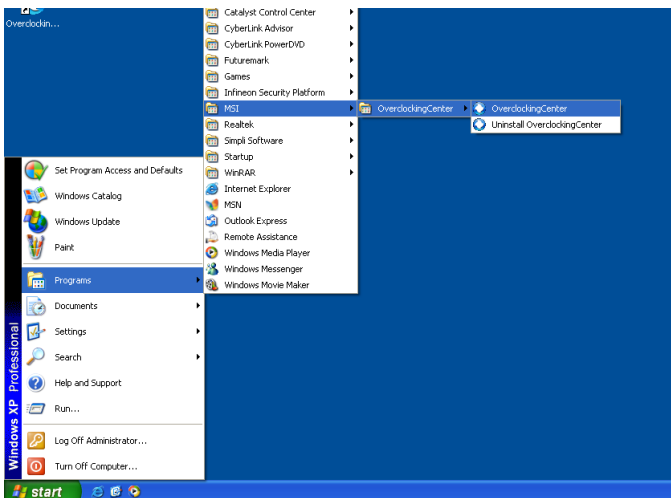

short-cut path in the start-up menu
(path: Start-->Program Files-->MSI-->Overclocking Center-->Overclocking Center)

SYSTEM INFO

In the System Info screen, you can read the information of motherboard/ PCI.

Motherboard

Click Motherboard to read the information of motherboard, BIOS, installed CPU and installed graphics card.

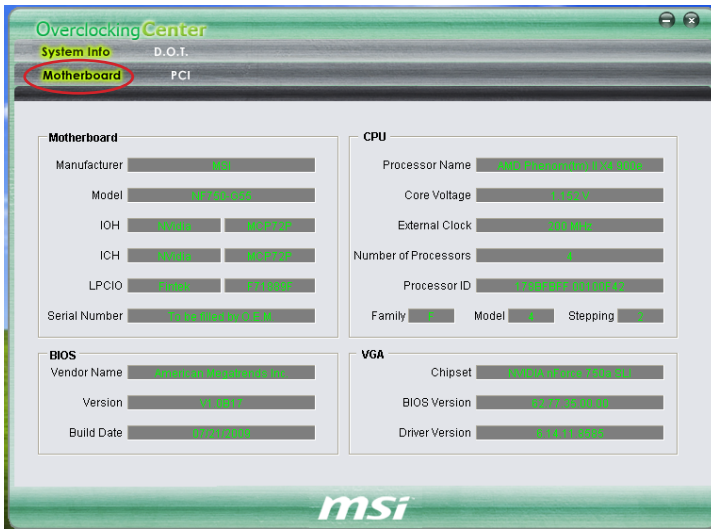

Important

The pictures in this appendix are for reference only and may vary from the product you purchased. Please refer to the appearance of your system for detailed information.

PCI

Click PCI to read the information of devices on the mainboard.

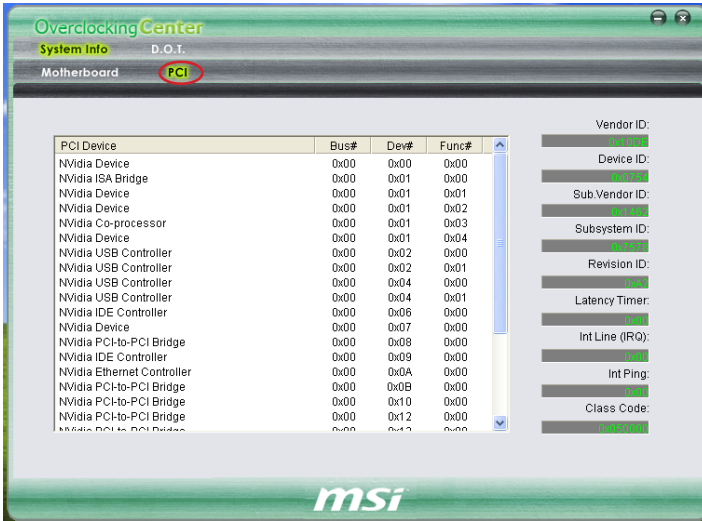

DOT

Click DOT to enter the DOT screen. In DOT, you can select the basic setting to reach optimal performance in Basic menu or you can adjust advanced values for overclocking in Advance menu.

Basic

In the Basic menu, it provides one default setting and several common settings for different environments. You may choose one of the settings that you need. The settings in Basic menu are not adjustable.

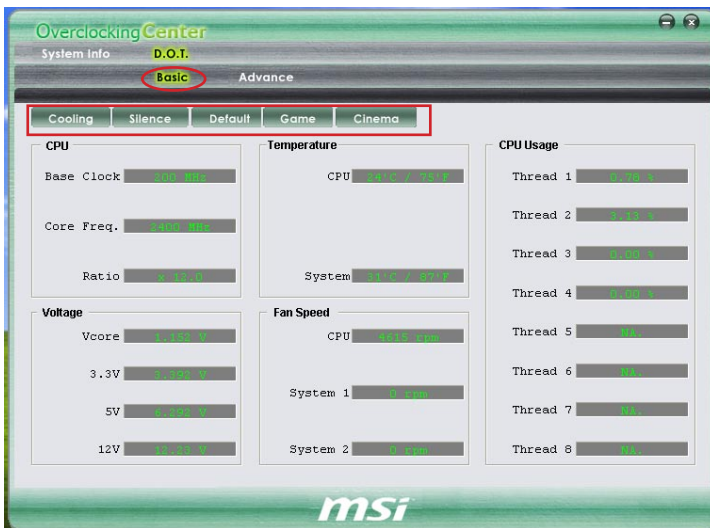

Important

You may change the values of each environment setting/ default setting in Advance menu. Please refer the following section for more details.

Advance

In the Advance menu, you can adjust the values for each environment setting/ default setting. Click the Cooling/ Silence/ Default/ Game/ Cinema button to enter its setting menu. Please refer to the following descriptions to adjust the values and save them.

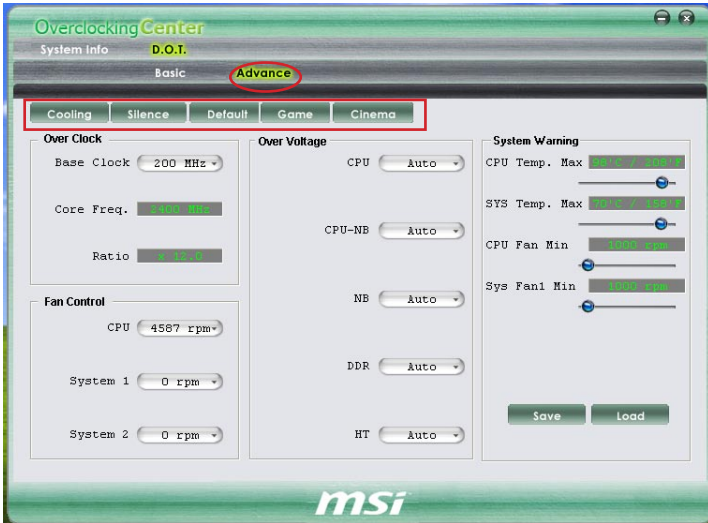

In each setting menu, you can select desired values for manual overlocking. Simply click the right side of the button which arranges an arrow sign, and a drop-down menu will appear below the button, then select a value.

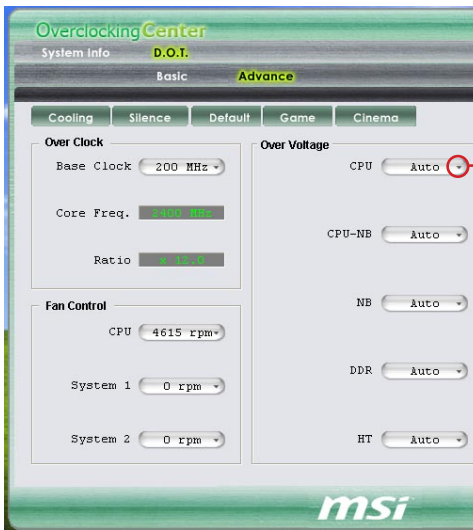

Click the arrow sign and the drop-down menu will appear.

In the “System Warning” block, you can set the maximum CPU/ system temperature and the minimum CPU/ system fan speed by using the scroll bar. The system will pop-up a warning message to warning you when the temperature/ fan speed is over/ lower the values you set.

Set the thresholds of CPU temperature & CPU FAN speed.

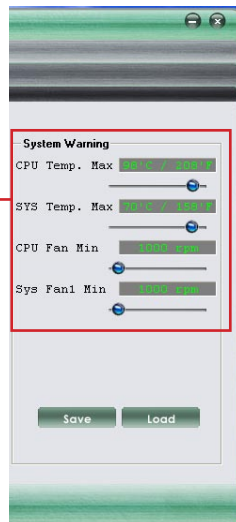

Overclocking Center

After you adjust the values in setting menu, you can save it for future use.

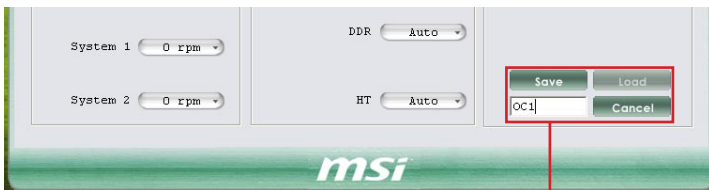

Click the Save button, and enter a name in the empty box. Then, click Save button again to save the settings.

Important

It provides you to save up to 20 user settings.

Click the Load button and choose a saved user setting to load the settings for the system.

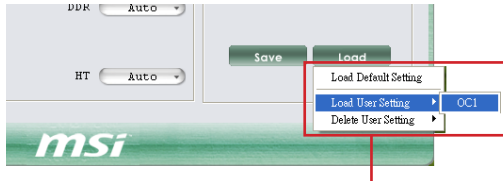

Click the Load button, and choose a saved user setting.

Important

Every time you turn-off the system, the settings will be restored to the factory default. If you want to use the saved settings, you have to load it after entering the operating system every time.